



HOUSE EXTENSIONS & GARAGES

DESIGN GUIDE

A companion to the Residential Design Guide



This guidance is a companion to the Residential Design Guide and is aimed at people wishing to extend or improve their home. This guidance sets out design principles which, when followed, will ensure good neighbourliness, an extension sympathetic to the existing house and in keeping with the local character.

T P Richards Dip T&RP, MRTPI, Head of Planning Services
PLANNING DIVISION
Department of Development Services, Knapping Mount,
West Grove Road, Harrogate HG1 2AE.
www.harrogate.gov.uk/planning

Harrogate
BOROUGH COUNCIL

Contents

Page

1. Introduction	1
2. Planning Policies	2
3. Components of Good Design	3
4. Site Appraisal	4
5. Survey	5
6. Siting Principles	6
7. The Principles of Form	7
8. External Appearance	8
9. Neighbour Effect	10
10. Front Extensions	11
11. Side Extensions	12
12. Rear Extensions	14
13. Dormer and Roof Extensions	16
14. Rooflights and Solar Panels	17
15. Basements, Balustrades, Walls and Fences	18
16. Outbuildings, Garages and Conservatories	19

Appendices

A. Permitted Development	i
B. Planning Policies and Designations	ii
C. Highway Issues	v
D. Relationship Between Buildings	vi
E. Building Form Composition - Side Extensions, and - Rear Extensions	x
F. Detail of Junction Between House and Extension	xii
G. Definitions	xiv
H. Consultation Process	xv
I. List of Useful Contacts	xvi
J. Application Checklist	xvii
K. Information required to be submitted with Application	xviii

1. Introduction

This guide is a Supplementary Planning Document which expands on saved policies H15 and HD20 of the Local Plan. The main purpose of this guide is to promote higher standards of design. A poorly designed extension can spoil the appearance of a house and the street scene, and can also detrimentally affect the neighbours. Planning permission will not be given if the design of an extension is unacceptable. This guidance sets out the basic design criteria that the Council would wish to see incorporated into home extensions.

Within this guide the term “extension” refers to any physical enlargement of a house, including conservatories, garages, car-ports, dormers in the roof and porches. The term “outbuilding” refers to free standing structures in the garden such as garages, sheds, stores and greenhouses, which are ancillary to the residential use.

This design guidance has been the subject of public consultation and is supplementary to the policies of the Harrogate District Local Plan. This guidance will be applied unless particular circumstances would dictate otherwise, however in all cases the criteria of Planning policies must be met.

The principles contained in this guidance are relevant whether Planning permission is required or not. See the Section on Permitted Development Rights, which explains the type of development that does not require Planning permission.

The Government sets out its Planning objectives in PPS1: "Delivering Sustainable Development" noting that Planning authorities should ensure high quality development through good design.

Local Planning authorities are responsible for the administration of Town and Country Planning Legislation. This is an important instrument in protecting our environment. Harrogate Borough Council determines all Planning and Listed Building Consent applications related to domestic extensions in this District. These applications are determined by assessing the proposals against Local Plan policies.

For further information on the planning process visit www.harrogate.gov.uk/planning

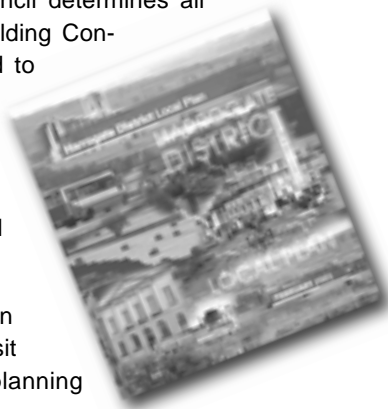

The Council must consider the appearance of the proposed extension, its relationship to the house and its surroundings, its impact on the amenity of neighbours and any other environmental issues that may be relevant to the particular site.

This guide addresses only Planning issues. It does not address other legal issues of development such as Building Regulations, the Party Wall Act, Rights to Light, the Human Rights Act and so forth. An agent, such as architect or surveyor, should be appointed to advise on planning, construction and design and certain legal issues, whilst a solicitor can provide specific legal advice. The Council can provide Building Regulations advice.



The six objectives of this document are:

1. to encourage exemplary design quality which minimises impact on the environment, particularly in sensitive areas (Core Strategy Objective);
2. to protect and enhance the built and natural heritage of the District;
3. to maintain local distinctiveness and enhance local character;
4. to protect residential amenity of neighbouring properties;
5. to maintain a safe and secure environment; and
6. to encourage sustainable building practices which minimise use of resources and waste production.

The key to the good design of a home extension which fulfils the Council’s objectives is to respond sensitively to the characteristics of the house and its surroundings.

2. PLANNING POLICIES

Government guidance in PPS1 states "Planning authorities should plan positively for high quality design." Good design should contribute positively to making places better for people. Design which is inappropriate in its context should not be accepted.

The Council determines applications for Planning and Listed Building Consent after assessing the proposals against Planning policies. These policies are set in the local plan, which at the time of publication is the Harrogate District Local Plan adopted in 2001 (including its Selective Alteration). This document provides a framework for rational and consistent decision making.

Key policies relevant to the design of home extensions are H15 and HD20. Other policies that may be relevant include those related to Listed Buildings and Conservation Areas, protected trees, Green Belt and other countryside issues. Further explanation is given in the appendix on Planning Policies and Designations.

H15 Extensions to dwellings

Extensions to dwellings will be permitted providing that all the following requirements are met:

- a) *There is no adverse effect on neighbouring residential amenity or property;*
- b) *There is no unacceptable loss of parking or garden amenity areas;*
- c) *There is no detriment to the character or appearance of the dwelling or the surrounding area;*
- d) *In the countryside the extension should not be designed to facilitate the sub-division of the dwelling into separate units nor undermine the retention of any occupancy condition.*



HD20 Design of new development and redevelopment:

Proposals for new development and redevelopment should take into account, where relevant, the following design principles:

- a) *New buildings should make a positive contribution to the spatial quality of the area and their siting and density should respect the area's character and layout.*
- b) *New buildings should respect the local distinctiveness of existing buildings, settlements and their landscape setting.*
- c) *New buildings should respect the scale, proportions and height of neighbouring properties.*
- d) *New building design should respect, but not necessarily mimic, the character of their surroundings and, in important locations, should make a particularly strong contribution to the visual quality of the area.*
- e) *Fenestration should be well proportioned, well-balanced within the elevation and sympathetic to adjoining buildings.*
- f) *The use and application of building materials should respect materials of neighbouring buildings and the local area.*
- g) *New development should be designed with suitable landscaping as an integral part of the scheme.*
- h) *Special consideration will be given to the needs of disabled and other inconvenienced persons, particularly in proposed developments to which there will be public access.*
- i) *New development should respect the privacy and amenity of nearby residents and occupiers of adjacent buildings.*
- j) *New development should maximise the opportunities for conservation of energy and resources through design, layout, orientation and construction.*
- k) *New development should through design, layout and lighting, pay particular attention to the provision of a safe environment.*

Development which is contrary to these design principles will not be permitted.

The term "development" in this policy applies to house extensions, and ancillary outbuildings of all types. In addition to extensions of significant size or small extensions such as dormers, development includes buildings of lightweight construction such as conservatories or timber chalets. The following guidance applies to all extensions, large or small, lightweight or robust.

All of this guidance is important but, for this topic, the following is/are of particular relevance:

- Appendix A: Planning Policies and Designations

3. COMPONENTS of GOOD DESIGN

Good design is an aim in the development process and the Council will reject poor designs. Planning policies provide basic principles to ensure that new development is not only well designed in itself, but also fits in well with its surroundings. The basic components of design are siting, form and external appearance and these are all interlinked - good design requires a holistic approach (the principle considerations of these three components, and their detailed application, are discussed later).

Siting

The siting of an extension should not be detrimental to the pattern of buildings and the spacing between them. Generally, rear extensions are preferable to those on the side, and front extensions are rarely acceptable. It is important to note there are circumstances where it is impossible to design an acceptable extension due to the sensitivity of the site, limited space or the relationship of neighbouring buildings.



Form of Building

The scale and form of extensions are critical to their acceptability. In most cases the extension must appear subservient to the original house and the extension should be smaller in width, depth and height than the existing property. The form should respond to that of the house, the extension should be well proportioned and create a satisfactory composition with the house and the setting.

External Appearance

Generally the materials should match those of the house in type, colour and detail. Windows should be well-proportioned and well-related within the elevation and generally, where appropriate, should match those of the house. Roof overhangs, gable treatment and chimneys should be consistent with those of the house.

Style

Design must respond to its context. However, this does not mean that design of new extensions must copy earlier styles. **The Council welcome contemporary design which respects local character.**

All of this guidance is important but, for this topic, the following is/are of particular relevance:

- 6. Siting Principles.
- 7. Principles of Building Form
- 8. External Appearance.

4. SITE APPRAISAL

A full appraisal of the existing house, the site and its setting should be carried out before making design decisions regarding a future extension.

The survey of the existing house, site and immediate neighbouring buildings should be a measured survey, which will provide a suitable basis for the drawings for the proposals. The appraisal of the setting is a visual/ photographic survey carried out to provide the designer with an understanding of the context.

After the appraisal has been carried out and the context and characteristics of the house and extension site are fully understood, a design can evolve that makes optimum use of the existing building and provides an extension that reflects the character of the building and adjacent properties. This survey information should be submitted with the Planning application.

It is important that the local “grain” should be understood. This is the relationship of existing buildings to the street and each other on plan, the massing of buildings and the spaces between them.

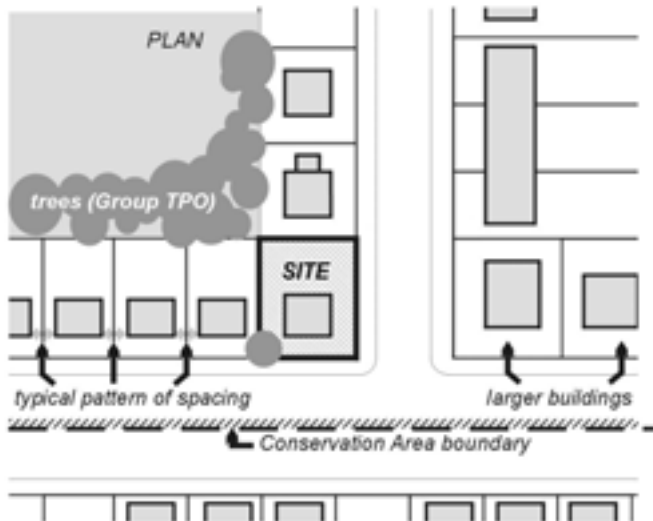

The “grain” of a settlement largely depends on the reason for its development, the era of its development and the topography. Two extreme examples are the character of the medieval centre of Ripon, where rows of buildings abut the narrow streets, and that of the late Victorian/early Edwardian Duchy estate, where large well-spaced villas are set back from wide streets and have generous mature gardens.

However, the majority of private houses in Harrogate District are within housing estates constructed in the twentieth century. Many of the examples given in the guidance relate to this character type.



Estate streetscene, late 20th century.



Village streetscene, 19th century.

5. SURVEY

To assist in design, the site survey should incorporate the following:

- The existing building. Scaled drawings, at a scale of 1:50 if practicable, of roof and all floor plans, section(s) and elevations;
- The site boundaries (at an appropriate scale) their positions and construction;
- Ground levels, indicating any falls across the site clearly;
- Trees - positions, spread, species and indication of condition;
- Ponds, wells, watercourses - position, normal depth and flood depth;
- Overhead wires - position and type;
- Drains, sewers and pipelines - position, depth and type;
- Walls, fences or hedges within the site - position, height and construction/species;
- Terraces, patios, paths - position and construction
- Access onto the site.

Survey information should also encompass sufficient property outside the site to show buildings and other features which will impact on design including:

- Surrounding buildings - position, size and aspects on plan. Section and elevations may be required to illustrate the impact of the proposed development on amenity or setting of neighbouring buildings;
- Trees - position, spread and species;
- Water courses - position, width and depth;
- Roads and neighbours driveways;
- Other features and adjacent land uses;

Research should be carried out to ascertain:

- Ownership of boundary walls. Whether there are Rights of Way or "easements" across the site;
- Designations - Listed buildings, Conservation areas, Ancient Monuments, Areas of Outstanding Natural Beauty, Tree Preservation Orders, Historic Parks and Gardens and so on;
- Planning Consents granted on adjoining land;
- Public sewers, supply pipelines, major electricity cables just outside the site;

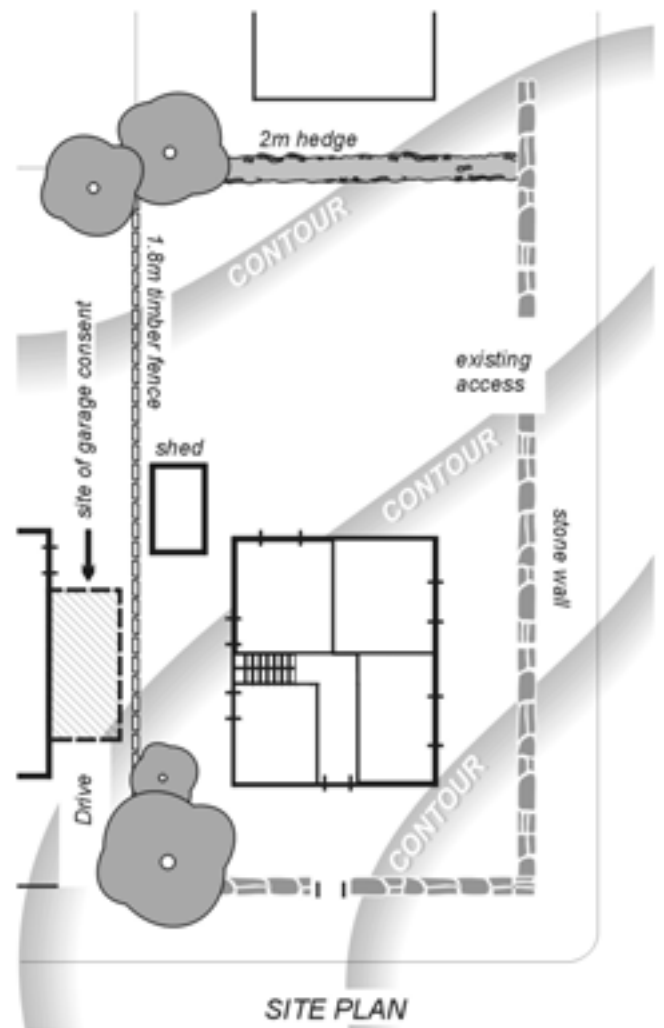

- Mining works, gypsum or other deposits that may affect the stability of the site;
- Risk from flooding (flood-proofing measures may be necessary).

Much of this information should be submitted with the planning application (please refer to the Planning Application Checklist & Notes for details - see: www.harrogate.gov.uk/harrogate-1030).

In conclusion, the surveyor should ensure that the existing house and all features of the site are either measured or noted. Full knowledge is crucial for a successful extension design that will harmonise with its environment, provide a positive contribution and will not impact on the amenity of neighbours.

All of this guidance is important but, for this topic, the following is/are of particular relevance:

- Appendix J: Information Required to Accompany Application.

6. SITING PRINCIPLES

New development should make a positive contribution to the character or spatial quality of an area. The siting of new development should respect existing building lines, the pattern of buildings and the spaces between them.



There are very few areas in the District where front extensions or projections are commonplace and therefore there is a strong presumption against extending the front of a house. Front extensions will only be permitted where frontal projections are commonplace in the immediate area.

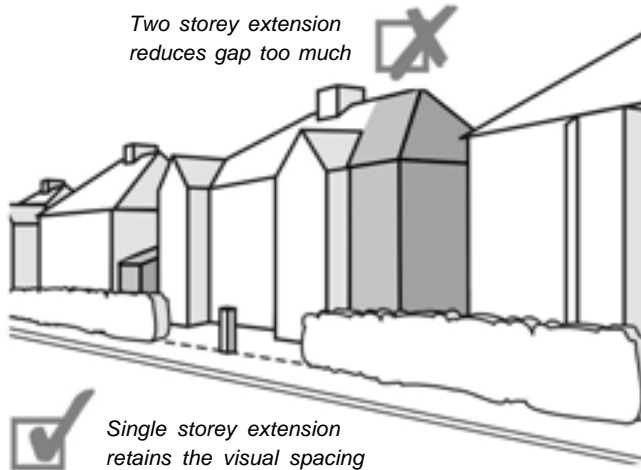

Extensions should not be sited against the side of a house where it would effectively fill or otherwise reduce the space between the house and its neighbour that is characteristic of the area.

The siting and orientation of extensions should avoid unacceptable levels of overlooking and overshadowing of private areas of neighbouring houses and gardens. New development should not overbear its neighbours (see guidance on Neighbour Effect).

Extensions should not result in the total loss of off-street parking or the majority of the garden/amenity area.

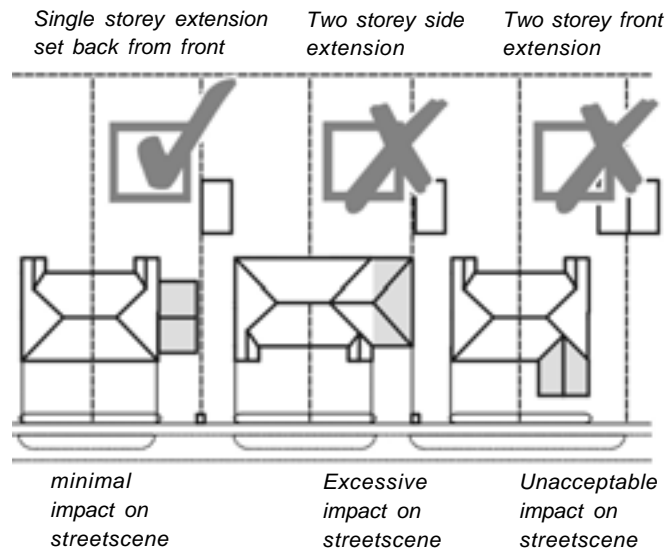

Extensions should be sited to preserve existing trees and hedges. Advice on acceptable distances between buildings and trees can be sought from the Council's Arboricultural officer and BS 5837.

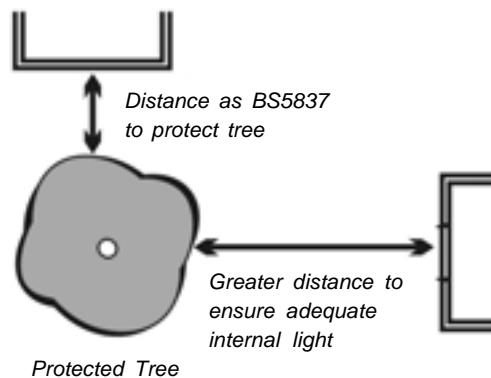

Extensions should not prevent the natural surveillance of surrounding properties and particularly front doors from the street. This will reduce the chance of criminal behaviour. North Yorkshire Police have Crime Prevention Officers who advise on community safety.

New development that is not sited in accordance with these design principles will be contrary to objectives 1-5 of this guidance and Planning policies related thereto.

All of this guidance is important but, for this topic, the following is/are of particular relevance:

- 4. Site Appraisal.
- 5. Survey
- 9. Neighbour Effect

7. The PRINCIPLES of FORM

The form of an extension is one of the most important factors of a successful design. The extension should reflect local distinctiveness in scale, proportions and height. An extension should normally be subservient to the original house except in exceptional circumstances when it is appropriate to "re-order" the house. The extension should not be larger than neighbouring houses. The scale and form of an extension should not overbear or cause unacceptable overshadowing of neighbouring properties.

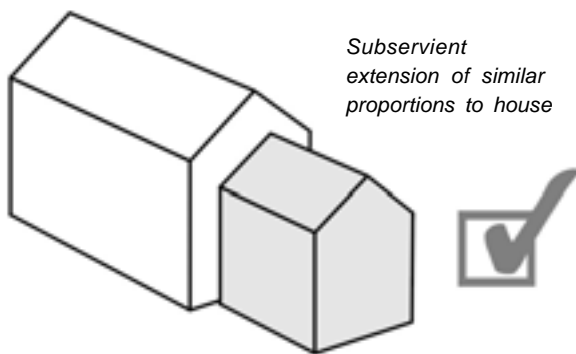

Buildings should not be subjected to continuous incremental growth. Whilst it may be appropriate to extend on one side of a house that has already been extended on another side, it is rarely acceptable to extend onto an existing extension, or link extensions which would then subsume the original building.

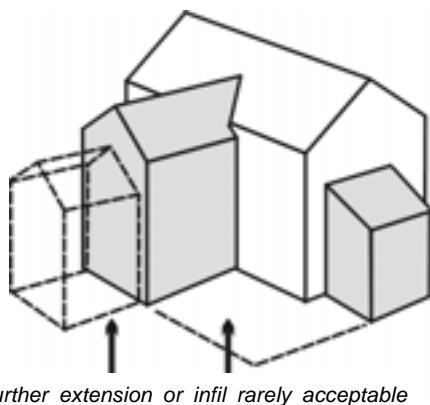

The form of an extension should be well-proportioned and present a satisfactory composition with the house. The forms of the house and extension should be in harmony, the combination not discordant (see further guidance on 'composition').

The proportions of both the individual element and combination of the elements of form should reflect existing buildings in the locality. Traditionally, unless a building is part of a terrace, eaves walls are longer than gable walls and frontage width is greater than height.

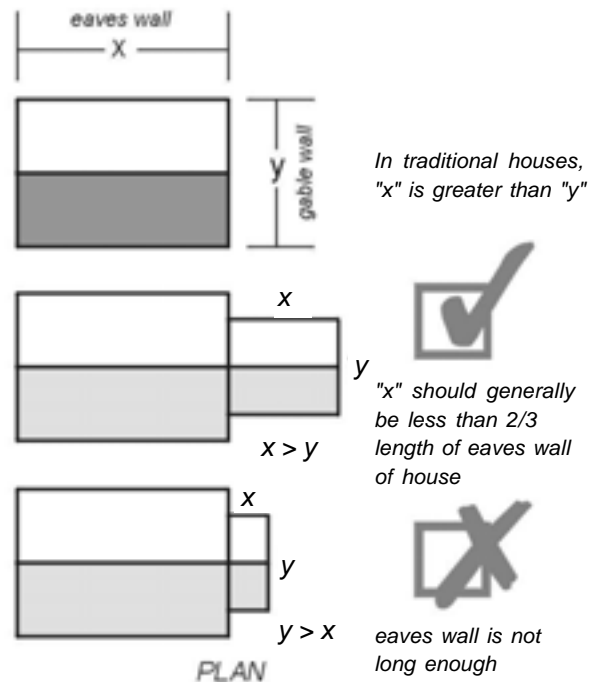

Roof shape is critical to massing. Flat roofed extensions are unlikely to be permitted. Hipped roofs should be used only on houses with a hip, or where local buildings have hips and the use of a hip is appropriate. The pitch of extension roofs should be as, or similar to, the house roof pitch.

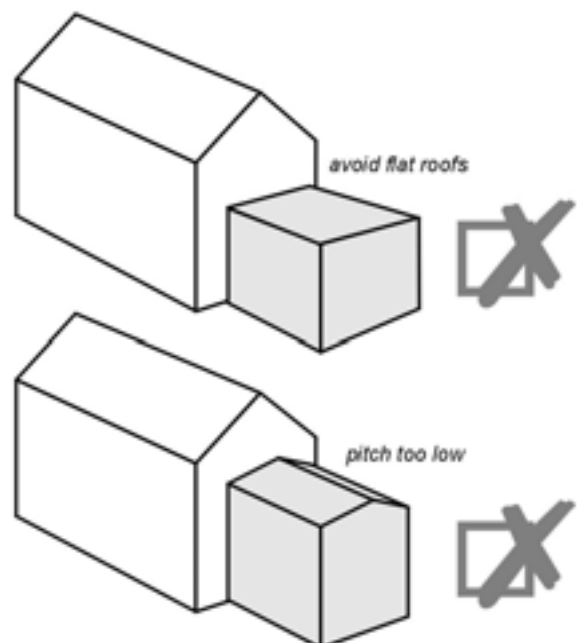

New development which has form contrary to these design principles will not be in accordance with objectives 1-5 of this guidance and Planning policies related thereto.

All of this guidance is important but, for this topic, the following is/are of particular relevance:

- 4. Site Appraisal
- 5. Survey
- 6. Siting Principles
- 9. neighbour Effect
- Appendix E: Building Form Composition

8. EXTERNAL APPEARANCE

The external appearance of an extension should be well proportioned, with fenestration well-balanced in the elevations and should respect the style and character of the original house. Windows should not be positioned so as to impact on a neighbour's privacy.

The proportions of the windows in an extension should generally reflect those of the original building. For example, an extension to a house with windows of vertical proportion should not have windows that are square or horizontal in proportion.

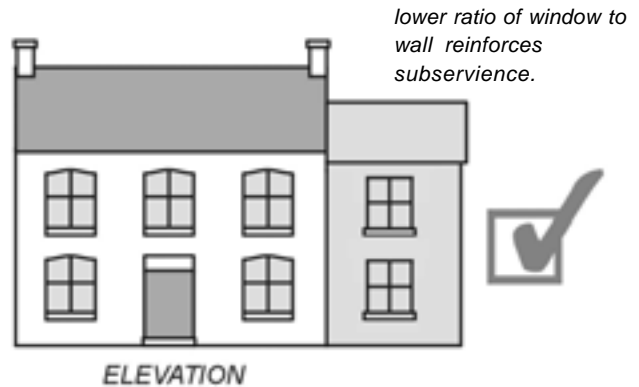

Traditionally houses had quite small windows and a large wall to window ratio. Wherever possible houses were orientated so that the main rooms and hence windows face south. Windows on the north side were limited in number and size. This was to maximise the warmth gained from the sun and minimise openings on the north to minimise heat loss. The principle of minimising heat loss through design is encouraged.

It is not always necessary to copy exactly the original windows, particularly when they are Georgian in style. However, it is important that an extension does not appear older than the original house, especially when extending older properties. Recently, there does appear to have been a return to historical styles, but with a lack of understanding of their essential design qualities. Replica period features of poor quality should be avoided.

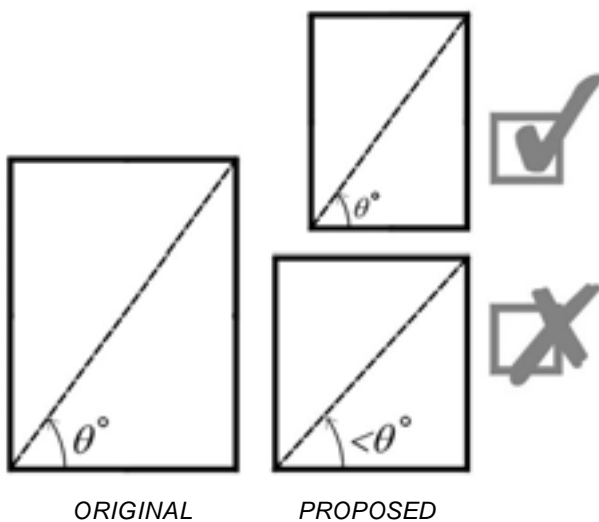

A simple way to replicate the proportion of a window, or other element, is to draw the diagonal and use this angle in the design of new windows.

Additionally the proportion or ratio of solid wall to window should reflect that of the house or local buildings. The number and size of windows in an extension should be limited to those absolutely necessary, otherwise the elevations appear too "busy" and over-fenestrated.



A mock-Georgian bay has replaced the original vertical sliding sash window - to the detriment of the facade.

The choice of building materials should reflect and reinforce the character of the area. Generally the materials of an extension should be as the house, however often secondary buildings or extensions were erected in less expensive or more easily available materials and hence,

All of this guidance is important but, for this topic, the following is/are of particular relevance:

- 4. Site Appraisal
- 5. Survey
- 7. The Principles of Form
- 9. Neighbour Effect

if it reflects the vernacular, it could be appropriate to use other local materials on an extension.

Materials should be sustainably sourced wherever possible. Consideration should be given to the use of recycled materials and for future recycling. For example lime based soft mortars prevent some weathering of brick or stone and their use allows a wall to be dismantled without the damage that hard cement mortars incur.



The use and application of materials should respect the local techniques and traditions and be in sympathy with the original house and neighbours as appropriate. For example, stone should be laid to course and course heights and block sizes should be as the original house.

However details can at times be simpler, it is not always appropriate to have prominent quoin blocks or richly detailed surrounds to doors and windows of a small extension for example. Similarly, it would be inappropriate to use stone lintels over windows in a brick extension to a house where there are no visible lintels, or there are brick arches.

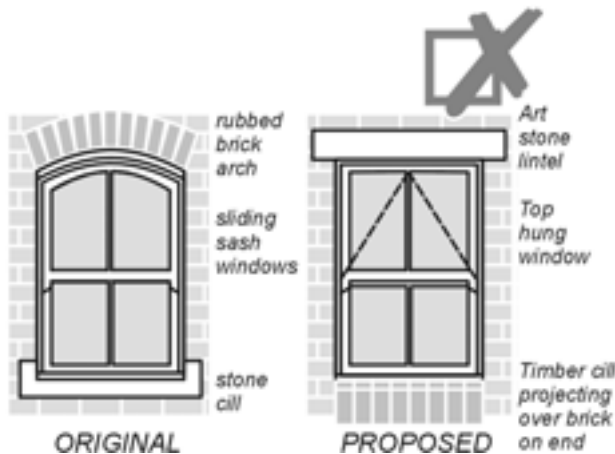

The window detail, including opening method, and depth of reveal should be consistent with those of the house if it is intended to replicate the style.

Generally, roof overhangs, gable treatments and verges should be consistent with those of the house. Where existing details are very ornate, for example where there is a heavy eaves overhang with a substantial dentilled cornice,

exact replicas would be inappropriate to a small extension and simpler details should be adopted.

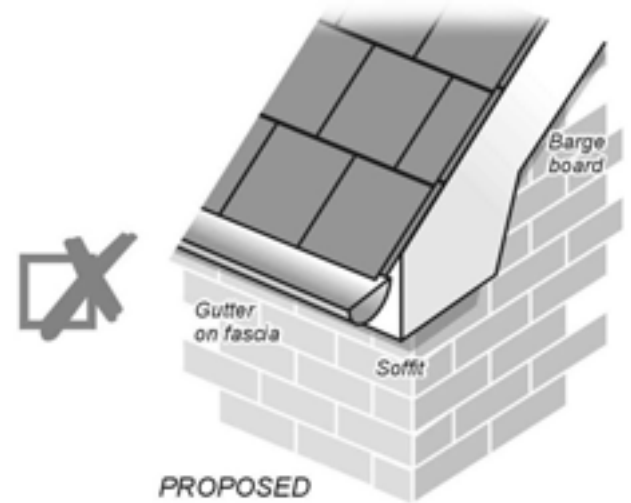
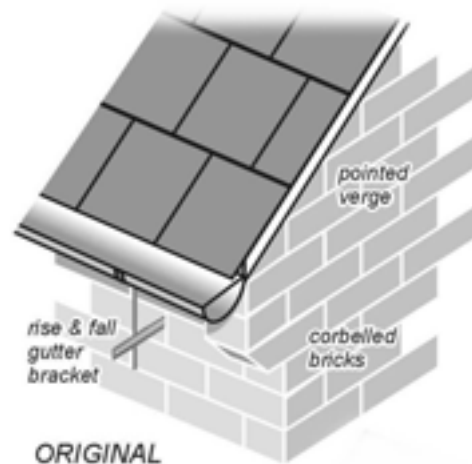

Roof lights and solar panels that lie flat against the roof are acceptable. To reduce visual impact these should be to the rear of the property, those to front slopes in Conservation Areas will be resisted (see the section on rooflights and solar panels regarding their size, siting and spacing).

Contemporary design, reinterpreting traditional forms and using traditional materials creatively can add to the richness and interest of an area. A sensitive designer can produce a modern extension which respects the original house and neighbouring buildings.

The design of new development which is not in accordance with these design principles will be contrary to all the objectives of this guidance and Planning policies related thereto.

All of this guidance is important but, for this topic, the following is of particular relevance:

- 14. Rooflights and Solar Panels

9. NEIGHBOUR EFFECT

An extension invariably results in part of a house lying closer to neighbouring property than before and its impact on the amenity of the neighbour needs careful assessment. Issues of privacy loss, overlooking, overshadowing and overbearing are to be addressed. When considering an extension, the owner should ask himself whether he would object to an extension of similar size, form or appearance next door. It is worthwhile to work out the effects of the proposed extension and discuss these with the neighbour to avoid misunderstandings.

Overlooking

Overlooking occurs where there is inadequate distance between windows in the development and a neighbour's windows or private amenity area resulting in an unreasonable loss of privacy. This can be accentuated if there are differences in ground level between adjacent properties, where greater distances between windows or to garden boundaries may be required.

Housing Estates of the twentieth century post-war were often designed with a separation of 70 feet (21m), which was accepted as a standard to ensure reasonable privacy. Ideally the distance between main reception room windows that face each other at the same level should be 21m. However in town centres this distance between buildings is impracticable and would be inappropriate to character.

The distances between windows to bedrooms can be a little less. Views of windows to bathrooms, which are usually of obscure glass, and kitchens are not so sensitive. The positioning of windows to give oblique views of neighbouring windows can resolve direct overlooking, and at ground level the use of screen walls can provide privacy.

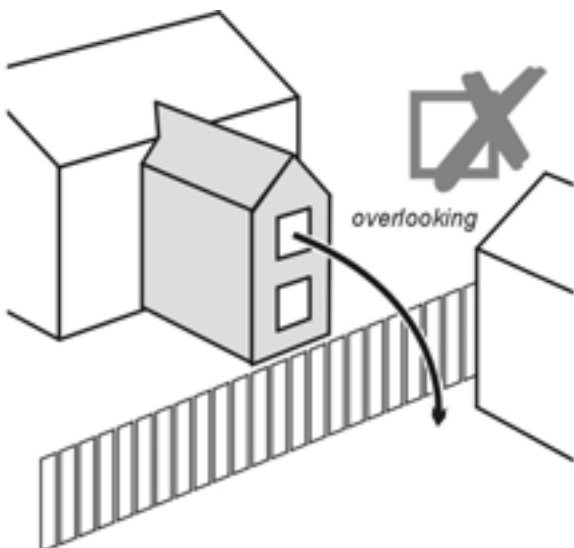

Overshadowing

Overshadowing occurs when the development is in such a location, or is of a size that would cause significant overshadowing of a neighbour's property or amenity space. The extent of overshadowing will depend on the orientation of the development, its size and position and the differences in ground level.

There are ways to assess the impact of proposals on neighbouring buildings. Guidance is provided in the Building Research Establishment publication: "Site Layout Planning for Daylight" written by P. J. Littlefair.

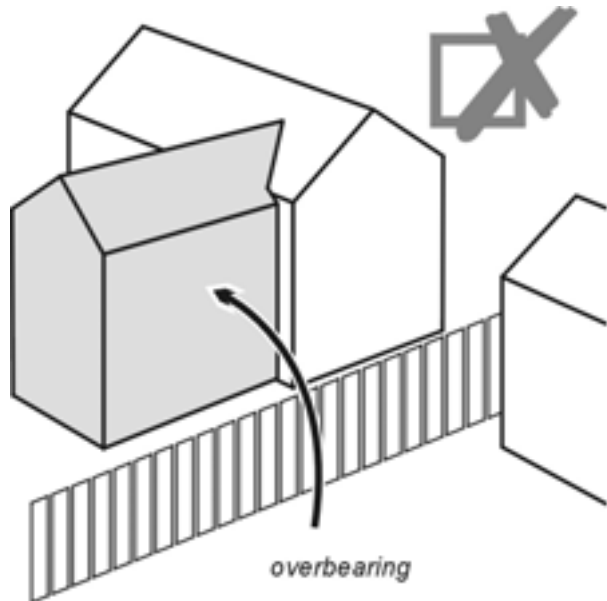

Overbearing

Problems arise when the physical presence of an extension is of such a magnitude in terms of overall mass (height, length and basic shape) and in such proximity to neighbouring property that it results in serious loss of amenity.

Usually overbearing occurs in addition to overshadowing, however if a new extension is on the north side of a neighbouring property there would be no overshadowing, but there may be overbearing. Any two storey extension should be set away from the boundary. The acceptable length of an extension will be determined by its height, the ground levels, distance back from the boundary and also the size of the neighbouring garden/amenity space.

Planning Law

Planning law does not lay down minimum levels of amenity, the Planning authority will aim to ensure that neighbours retain a reasonable degree of privacy and daylight.

All of this guidance is important but, for this topic, the following is of particular relevance:

- Appendix D: Relationships Between Buildings

10. FRONT EXTENSIONS

Generally there will be a presumption against extensions at the front of a property due to the need to protect the character of existing street scenes. A front extension can appear unduly prominent and incongruous where buildings are set back regimentally from the street. Front extensions may be acceptable in locations where it would suit the building style and also there are varying distances between houses and the street.



Porches would not be acceptable on this type of property.

Common proposals for extensions at the front of houses are for porches. These are only acceptable if they are not detrimental to the character of the street. Porches should not project excessively from the front of the house. The porch extension should not conflict or visually compete with existing features such as bay windows. The size and shape should respect the height and proportion of the original dwelling.

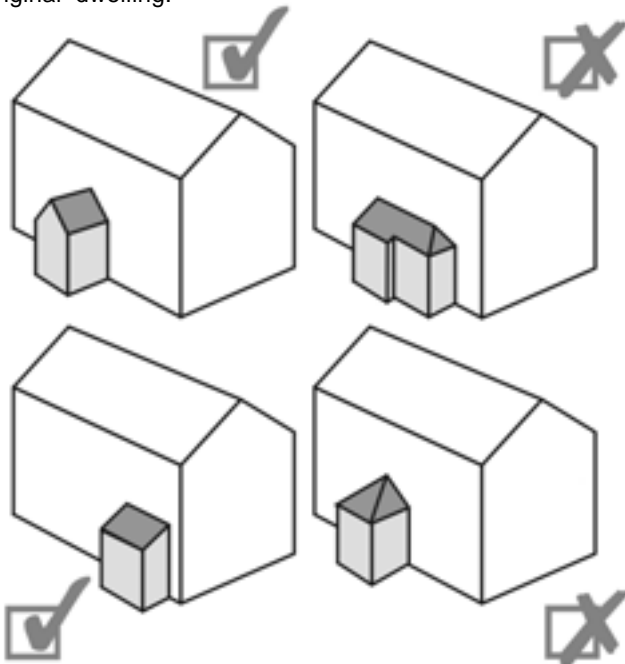

On attached houses, where front doors are paired a joint scheme should be considered. The risk of creating an eyesore is greatest within a terrace where an unsuitable porch can spoil the appearance of the whole row, if several different porches are added, the visual integrity of the whole terrace can be lost.



Larger front extensions will rarely be appropriate at the front of a traditional dwellinghouse. However in a street where there is variety and particularly where there are projecting elements with gables facing the street, a front extension to reflect those may be appropriate.



Properties with projecting front gables.

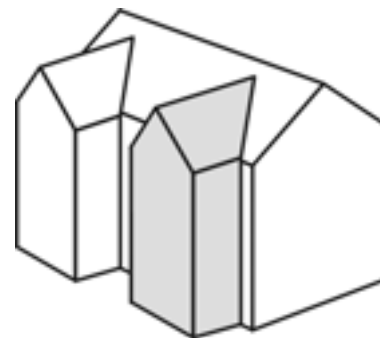

New (right hand gable) front extension is appropriate here.

The appearance of bungalows can sometimes be improved by totally reordering the building to make use of the roof space and, if it reflects local character, a projecting gable might be acceptable.

All of this guidance is important but, for this topic, the following is/are of particular relevance:

- 4. Site Appraisal
- 5. Survey
- 6. Siting Principles
- 7. The Principles of Form
- 8. External Appearance

11. SIDE EXTENSIONS

Provided that the design principles before described have been followed, a single storey extension to the side of a property should be acceptable if it does not impact uncharacteristically on the nature of the space between buildings. When assessing proposals for two storey side extensions the Council will seek to prevent the loss of gaps between buildings, particularly where the gaps are important to the character of the street. This is to prevent two storey side extensions on houses creating the appearance of a terrace.



Extension set well back and reflecting the original form of the house.

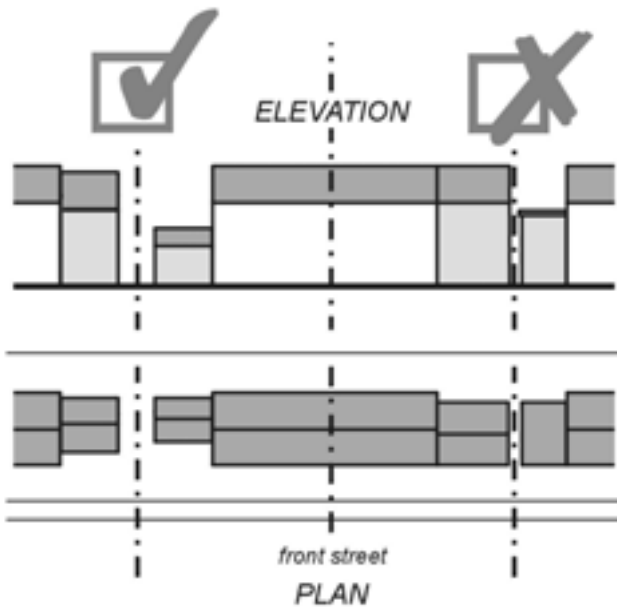

Side extensions should not involve total loss of existing off-street car parking unless adequate provision exists elsewhere within the domestic curtilage. The removal of the front boundary wall or hedge and the development of the front garden into a forecourt for parking is discouraged.

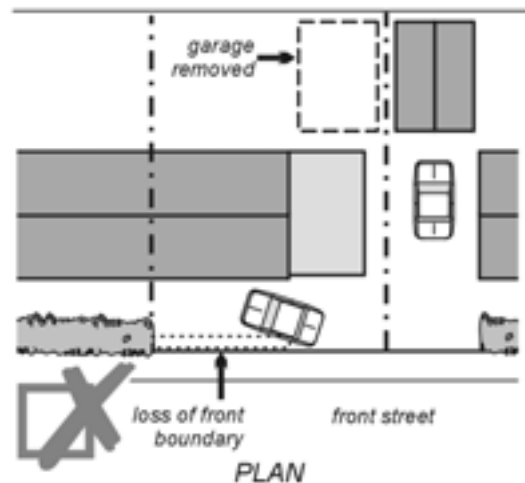

Prominent flat-roofed extension is visually detrimental.

Extensions on corner plots should be set back to respect the street scene and have suitable boundary treatments.

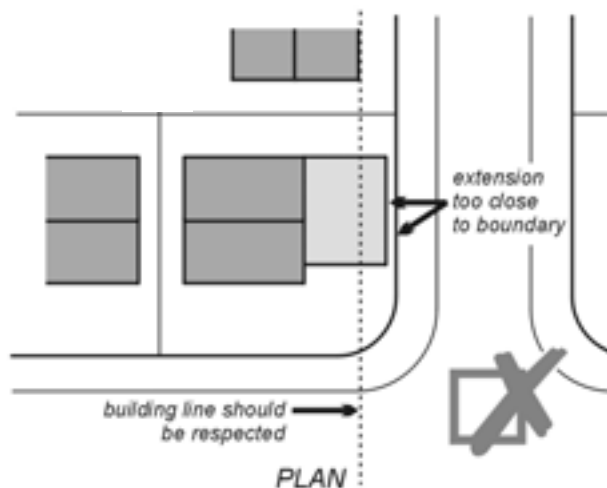

The extension should not lead to a significant loss of sunlight or daylight for adjacent properties.

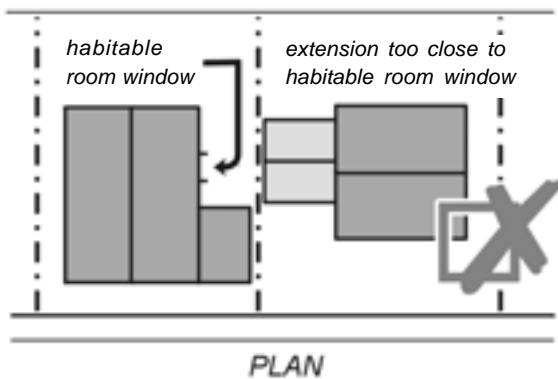

Windows should be located to avoid overlooking directly into neighbouring properties, including their private gardens. Proposals that would result in unacceptable loss of outlook and a sense of oppressiveness (overbearing) for neighbouring residents will be refused.

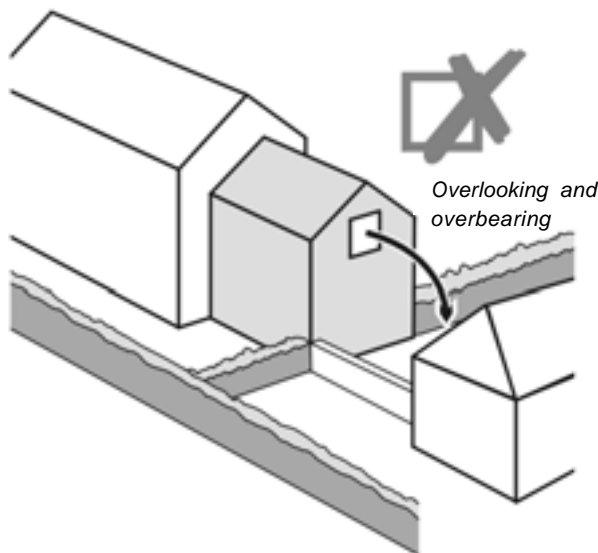

Where adjacent property enjoys a private garden to the side of a new extension, unless it is set away from the boundary, a large side extension will be overbearing.

Generally, a fully glazed conservatory or sun room on the side of a house will not be appropriate if it faces onto the street.

Unless appropriate to the design (and using materials which match exactly) the ridge of a side extension should be lower than the ridge of the original house to maintain architectural integrity. Ideally the eaves should be at a lower level, but this depends on the roof detail as sometimes it is visually inappropriate to step down the eaves when there is a large roof overhang. The extension roof should match that of the original house in material, form and detail.

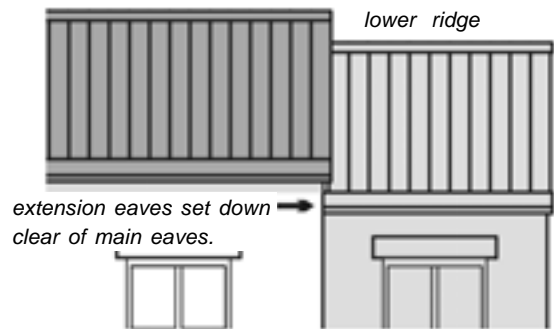

Almost always the front wall of the new extension should be set back from the face of the original dwelling. A setback reduces the impact of the extension and maintains the architectural integrity of the original building. Also as it is rarely possible to accurately match the original materials, the set back disguises the junction of old and new. The dimension of the set back is dependant on the walling material and roof detail. See appendix on details. An extension that incorporates a garage should be set back as far as possible in order to decrease its visual impact on the streetscene, see appendix on highway issues. In exceptional circumstances a setback may be omitted - if the building is to be "re-ordered", or if materials are used which match exactly those of the original house and the extended building retains architectural integrity.

All of this guidance is important but, for this topic, the following is/are of particular relevance:

- 4. Site Appraisal ● 5. Survey ● 7. The Principles of Form ● 8. External Appearance
- 9. Neighbour Effect ● Appendix D: Relationship Between Buildings

12. REAR EXTENSIONS

The form of an extension to a traditional building should generally reflect local examples. Extensions should not significantly reduce the amount of daylight and sunlight enjoyed by neighbouring properties.

Rear extensions have less immediate impact on the streetscene than side extensions. However the additional mass of an extension does impact on the space about buildings, which is an important consideration, especially in Conservation Areas.

Two storey extensions on terraced properties with limited rear gardens will generally not be acceptable due to the impact on neighbouring property and sometimes almost complete loss of amenity space for the house it is wished to extend.

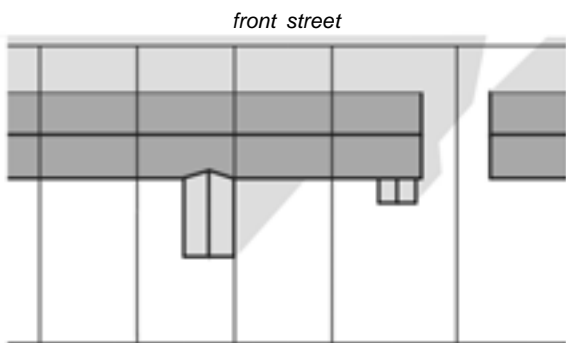

PLAN

*unacceptable
overshadowing
of neighbour*

*no over-
shadowing*



ELEVATION

It is recommended that neighbours combine extensions to provide mutual benefits.

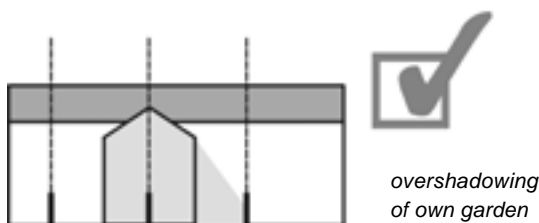

The Council will seek to maintain adequate distance between habitable room windows of one property and a blank flank wall of an extension to ensure adequate amenity.

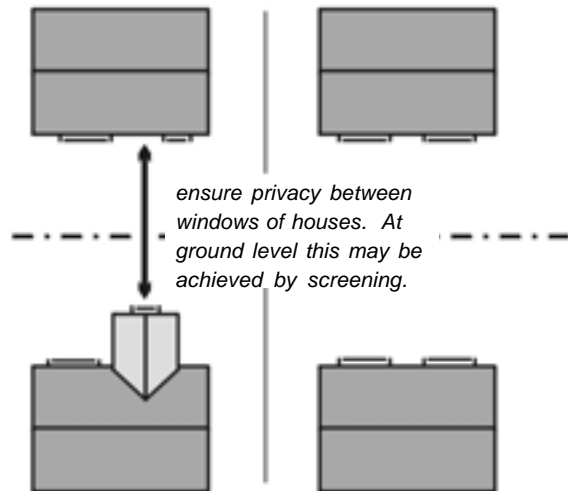

The Council will seek to maintain adequate distance between habitable rooms in properties that stand back to back with each other to maintain privacy.

Although less common, proposals may come forward for three storey extensions. The potential for such proposals is increasing because three storey town houses are now commonly built so that efficient use is made of land. Any proposed extensions on such properties will be assessed against the general guidance in this document.

Windows shall be located to avoid overlooking directly into neighbouring properties, including their private gardens. Proposals that would result in unacceptable loss of outlook and a sense of overbearing for neighbouring residents will be rejected.

Roof of Extension Perpendicular to House:

The gable width of an extension should be smaller than that of the house. The gable of the extension should have similar proportions to that of the house gable even though it is of smaller scale. The roof pitch should match the house roof except where different roofing materials are to be used on single storey extensions when appropriate to the context.

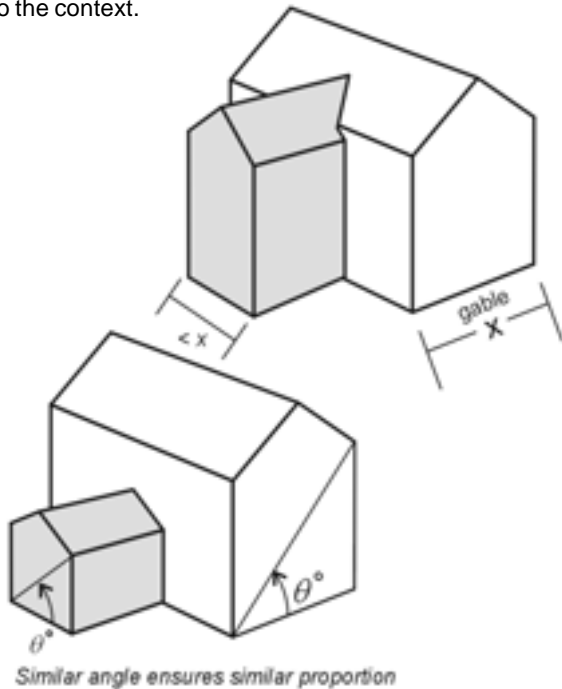

Lean-to Extensions:

The width of an eaves wall of a lean-to should always be greater than the depth. As a general rule, the depth of a lean-to that is an extension of the house roof should be similar to half the depth of the house.

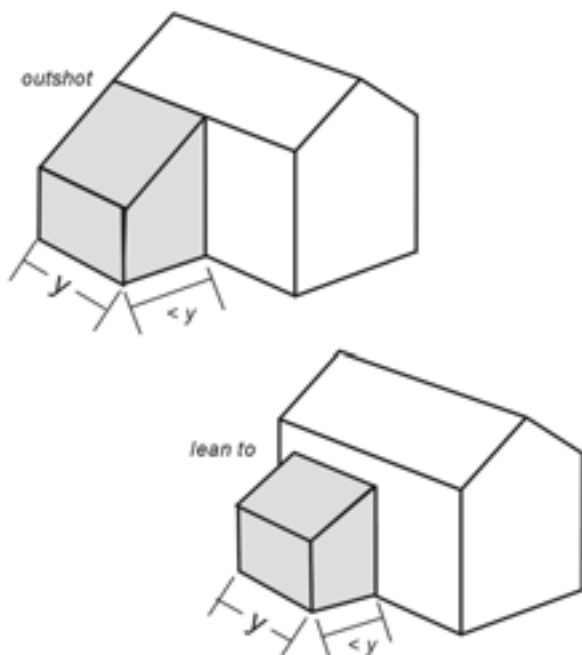

Hipped Roof Extension:

The extension should be well set back, otherwise the extension roof should be in line with the house roof and all roof tiles replaced.

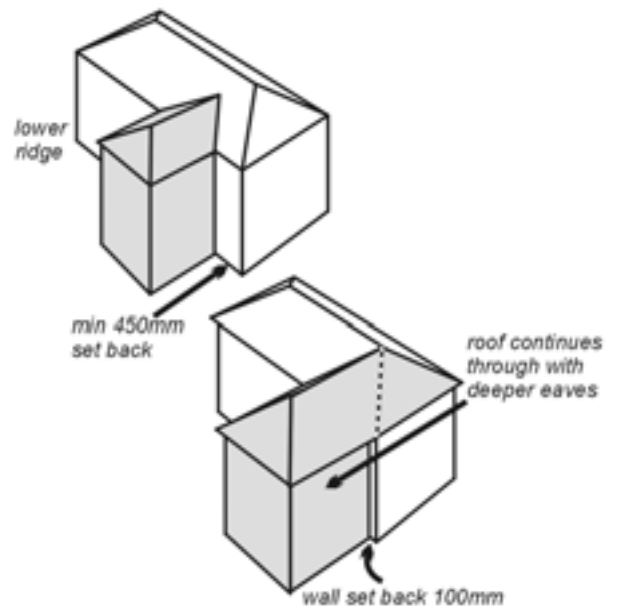

Generally the side wall of a rear extension should be set back from the side wall of a house. This maintains the architectural integrity of the original building and disguises the junction of old and new materials. This setback can only be omitted if exactly matching materials are used and it is suitable to the building design.

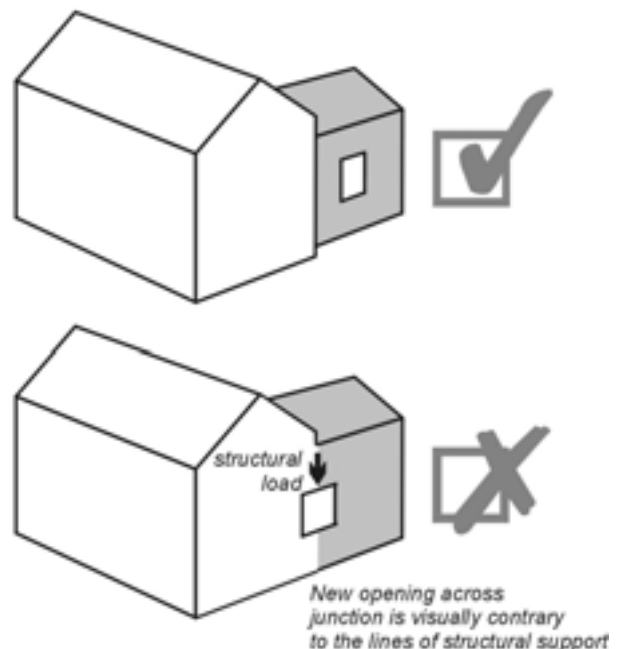

All of this guidance is important but, for this topic, the following is/are of particular relevance:

- 4. Site Appraisal
- 5. Survey
- 7. The Principles of Form
- 8. External Appearance
- 9. Neighbour Effect

13. DORMER and ROOF EXTENSIONS

The Council will seek to restrict the location of dormer windows to the rear of a dwelling in order to preserve the character of the street. New front dormers will not be allowed in streets where there are no dormers. Side dormers will be allowed only where they do not impact uncharacteristically on the nature of the space between dormers. Any dormer that results in unacceptable overlooking of a neighbouring property will not be permitted.

Where dormers are acceptable they should not be so numerous or large that they dominate the roof.

Wide, flat-roofed dormers are generally unacceptable. Occasionally, small, flat-roofed dormers are appropriate to the style of a house but, generally, dormers should have pitched roofs with gables parallel to original wall below, or where appropriate to local character catslide roofs. Dormer ridges should be set down from the ridge of the original roof.

The face of a dormer should be set back by a minimum of 1m behind the original wall. A dormer should be set in from side walls including party walls of a house.

Small pitched dormer set well back from eaves, down from ridge and in from sides

Dormer face at eaves, ridge too high and too close to party wall

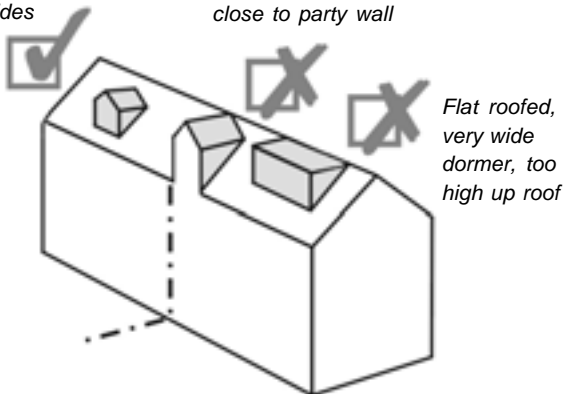

Dormer extensions should never project above the original ridge line.

it is very difficult to accommodate dormers within low hipped roofs.



Dormer windows should seek to line up vertically with existing windows and match their style and proportions.

Properties with limited roof space due to shallow pitches may be unable to incorporate dormers successfully. Large dormers that are disproportionate to the house will not be allowed, as a major part of the roof plane should remain unaffected by the proposal.

Increasing the roof height of a dwelling by altering the eaves height or the pitch can have a significant impact on the dwelling and streetscene. Also, it is very difficult to match the walling materials adequately. Neither would be acceptable in a terrace, or a street in which all heights and roof pitches are the same.

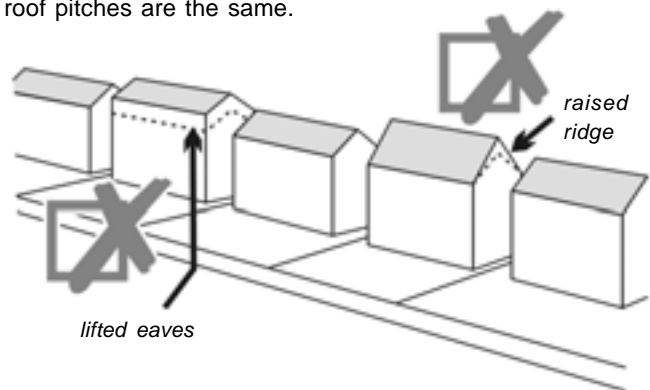

Materials used for dormers and roof extensions should complement the existing roof material. The roof should match the original roof. Side cheeks should be of vertically hanging tiles, or of lead.

The Council encourage the conversion of existing flat roofs to pitched roofs, except where they are appropriate to house style.

Proposals to use part of the roof as a balcony often cause loss of amenity of neighbouring properties caused by overlooking of their private garden areas and of habitable room windows. Balconies that would cause this loss of amenity will not be permitted. Horizontal balustrades and roof voids as shown below create an alien form and are rarely acceptable.

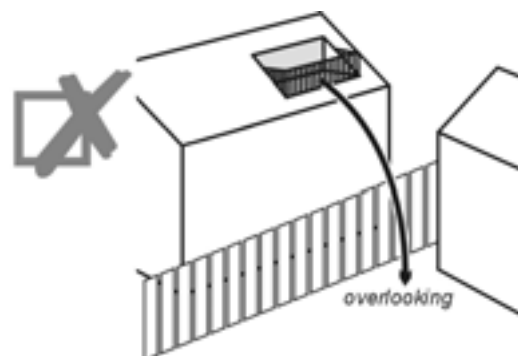

All of this guidance is important but, for this topic, the following is/are of particular relevance:

- 4. Site Appraisal
- 5. Survey
- 8. External Appearance
- 9. Neighbour Effect
- 14. Rooflights and Solar Panels

14. ROOFLIGHTS and SOLAR PANELS

Rooflights should be restricted to the rear or least visible slopes of the roof wherever possible and particularly in Conservation Areas or the Area of Outstanding Natural Beauty. Rooflights should not result in unacceptable loss of neighbours' privacy

The size and number of rooflights should be restricted to the minimum required by Building Regulations. Wide rooflights are detrimental to the appearance of a roof, therefore the width should be 550mm or less unless the rooflight is to be a fire escape.

Rooflights should be ideally set within the middle third of the roof slope. Also they should be set away from the gables (verges) or roof abutments and from chimneys or dormers. If there is to be more than one rooflight, they should be set at the same level and evenly spaced.

In general, rooflights should not be sited opposite each other on both roof slopes near to the ridge or on a small roof. This is to prevent daylight penetrating and appearing as a hole clear through the roof that is detrimental to its appearance.



Two rooflights on opposite slopes of the roof resulting in an apparent 'hole' in the roof.

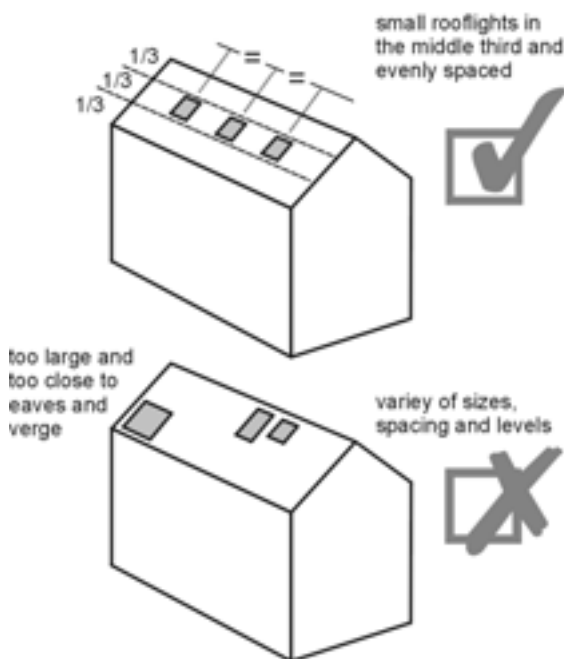

To minimise their impact on roof shape, rooflights should be as flat against the roof as possible and conservation lights or those using similar flashing systems should be used.

Siting of solar panels should follow the same principles as rooflights; on least visible slopes, in the middle third and away from verges. However as their efficiency is dependant on orientation, siting on the rear slope might prove ineffectual and hence consideration may be given to siting solar panels on more visible slopes. Highly visible solar panels may not be acceptable in sensitive locations such as Conservation Areas and the AONB or on listed buildings.

Escape rooflights must meet the recommendations of the Building Regulations. The cill should be not less than 800mm nor more than 1100mm above the floor level. If the resultant position on the roof presents a detrimental appearance, the rooflight may be unacceptable especially in sensitive locations.

Solar panels should be as flat against the roof as possible so that they have little effect on the roof profile.

Solar tiles may be permitted, samples should be provided to enable Planning officers to advise on their acceptability before they are specified.

All of this guidance is important but, for this topic, the following is/are of particular relevance:

- 8. External Appearance
- 13. Dormer and Roof Extensions

15. BASEMENTS, BALUSTRADES, WALLS and FENCES

The use of basement space is sustainable and is generally encouraged by the Council. Planning permission is not required for the use of a basement to form ancillary habitable accommodation for a private house, however lowering the floor to provide extra headroom will require permission.

The major impact of using a basement as habitable accommodation is the requirement for light and ventilation, which generally results in new windows and lightwells. A balustrade across a front garden can be a very disruptive element in the streetscene and may be unacceptable.

The “balustrade” is the protecting vertical element, which prevents persons from falling over the edge of a stair, landing, balcony or upper floor/ground level. It may be open in appearance, such as a railing, or solid, such as a wall, in appearance. Balustrades should be designed as appropriate to their setting.

The lowering of external ground levels should be minimised to reduce or obviate the need for a balustrade. Wherever possible the garden should be graded so that the balustrade is not required. Insertion of unnecessary doors or French windows below natural ground level should be avoided. Where a view out is unnecessary, the lightwell for the window can be protected by a horizontal grille at ground level that can be removed for maintenance.

Generally to ensure maximum daylight for the basement room, balustrades are open. Simple vertical railings are usually appropriate and their design should be as light and elegant as possible. In general, very ornate wrought iron railings should be avoided, the design should be based on local traditional examples adjusted as required under current building regulations.

Commonly the excavation for a lightwell exposes masonry that was not built to be seen and is not of the same quality or material as the house wall above. The wall area to be left exposed is either to be rebuilt or refaced to match the wall above. If the wall is refaced, it should be designed as a plinth which should be extended up and across as appropriate to the house.

Retaining walls for lightwells, balustrade and boundary walls should be constructed of the same materials as the house or local boundary walls. The detailed construction should be based on local traditional examples in order to maintain or enhance local distinctiveness.

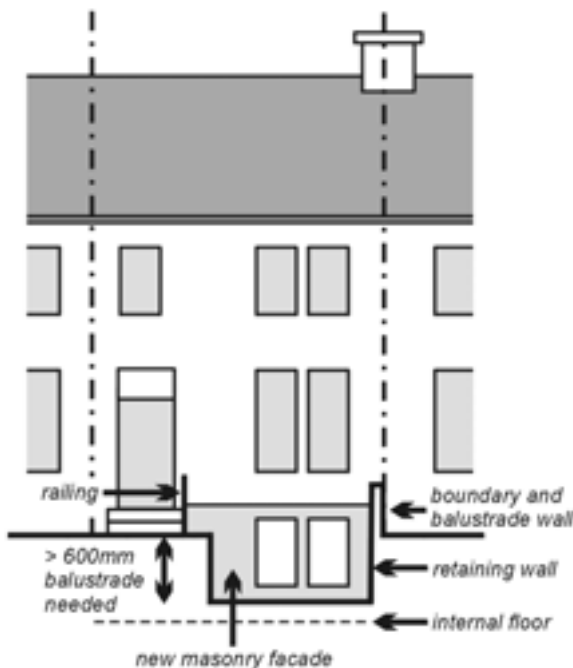

Iron railings lead into stone coping.

New 2m high timber panel fences used as screens to maintain privacy for neighbours are generally acceptable in back gardens, however in sensitive locations, such as the boundary to a Listed Building or in a Conservation Area, the screen should be of brick or stone as appropriate to the setting.

Generally timber panel fences to boundaries with the public highway or at the edge of settlements will not be accepted. See also section on highway issues. Boundary construction should reflect local tradition, this may be railings on a low wall, brick, cobble or coursed stone walls with vernacular details.

Similarly, balustrades to ramps (to provide access for the disabled) should reflect local tradition.

All of this guidance is important but, for this topic, the following is/are of particular relevance:

- 4. Site Appraisal
- 5. Survey
- 8. External appearance

16. GARAGES and OTHER OUTBUILDINGS

Outbuildings should not impact detrimentally on the space about buildings. Neither should they result in the loss of trees or other features that are important to the area. An outbuilding must be smaller in scale and clearly ancillary to the house.

Outbuildings, including garages, should normally not be in the front of domestic properties unless within developments where there is irregular arrangement of buildings. Outbuildings should not be over-dominant in relation to the existing and surrounding properties.

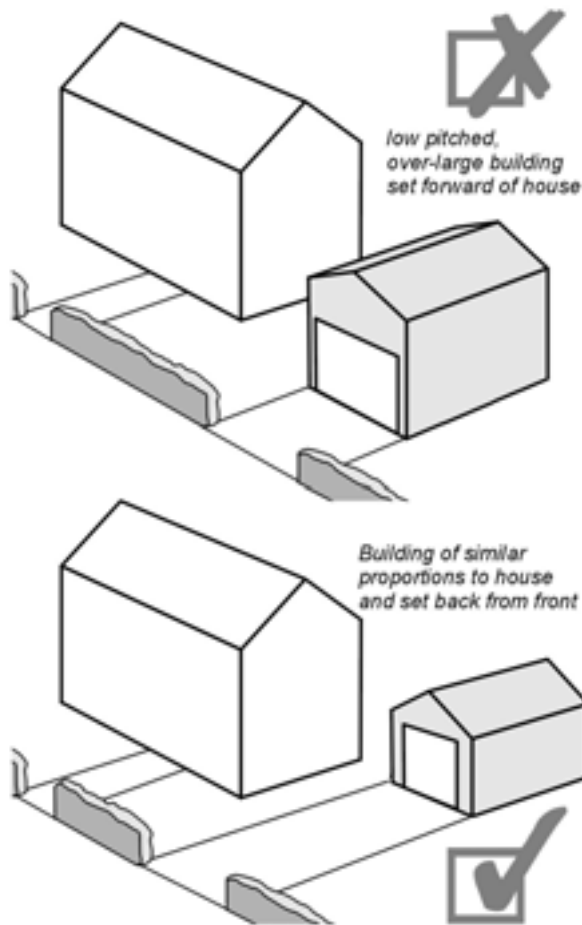

Outbuildings should reflect the style, shape and architectural features of the original house and be of matching or complimentary materials. In certain areas of Harrogate District, outbuildings are traditionally roofed in pantiles irrespective of the material of the main roof.



Outbuilding with pantiled roof against house with a slate roof.

Garage doors should be set back to reduce its visual impact on the streetscene particularly in sensitive areas. Garage doors should be single car width to reduce their visual impact. See appendix on highway issues regarding distances and access.

The Council will seek to ensure that new outbuildings do not have a detrimental impact on neighbouring properties, such as excessive overshadowing of a garden or principle window.

A tall building in this location would significantly overshadow the neighbour's small garden in the afternoon.

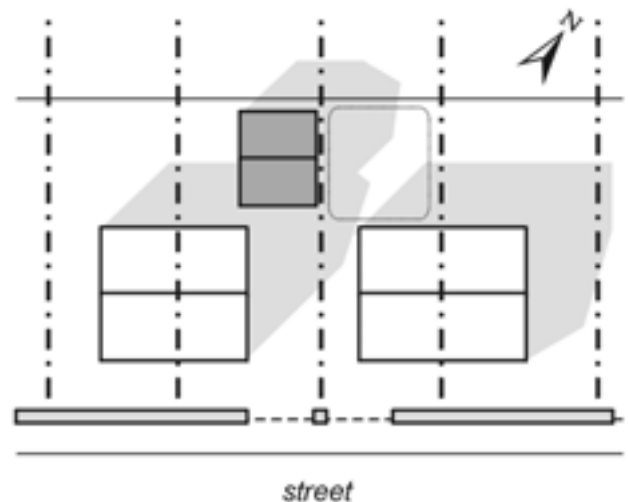

All of this guidance is important but, for this topic, the following is/are of particular relevance:

- 4 Site Appraisal ● 4. Survey ● 6. Siting Principles ● 7. The Principles of Form
- 8. External Appearance ● 9. Neighbour Effect

APPENDICES

A. Permitted Development

The principles contained in this guidance are relevant whether Planning permission is required or not. Certain extensions to houses do not require Planning permission because they are regarded as permitted development. Permitted Development Rights extend only to houses and not flats. There is a booklet that explains "permitted development rights", it is entitled "Planning - A Guide for Householders: what you need to know about the planning system" and is available at Planning Enquiries and on the Office of the Deputy Prime Minister's website www.odpm.gov.uk.



It may be that permitted development rights have already been used up by previous extensions, or removed by a condition on a previous Planning permission. Therefore it is important to check before making any assumption that an extension is permitted development.

Conservation Areas

Permitted development rights are reduced if the house is in a Conservation Area in order to preserve the special character or appearance of the area. The additional controls are as follows:

- a) Reduced volume of extensions;
- b) All dormers require Planning permission;
- c) Any outbuilding greater than 10m³ requires consent;
- d) Works to trees must be notified;
- e) Demolition of buildings, or part thereof and certain walls.

The Council can impose further restrictions in Conservation Areas under Article 4 of the Town and Country Planning (General Permitted Development) Order. These are commonly known as Article 4s. Typically these might restrict porches or the use of PVCu windows or concrete roof tiles. At the time of publication there are no Article 4s

in Harrogate District, however it is advisable to consult Planning Enquiries to ascertain whether the house is in a Conservation Area and, if so, whether there are any Article 4s in place.

Nidderdale Area of Outstanding Beauty (AONB)

As in Conservation Areas, permitted development rights are reduced if a house is within the AONB. The restrictions relate to volume of extension or outbuilding and all dormers require planning consent.

Listed Buildings

All external and internal alterations and extensions to Listed Buildings require a separate consent.



If you have any doubts whether your proposed extension would require Planning permission the Council offers a free pre-application checking service for householders. You can download this "Householder Planning Checklist Form" from our website page at www.harrogate.gov.uk/harrogate-1030 . Or contact our Planning Enquiries (phone 01423 556666) and ask for a copy.

B. Planning Policies and Designations

Policies

At the time of publication of this guide, the Local Plan is the Harrogate District Local Plan, which was adopted on 19 February 2001. Key policies relevant to the design of home extensions are H15 and HD20. The text of these two policies is included in this guide following the Introduction.

Policies that are or may be relevant to house extensions include:

- A1 Impact on the Environment and Amenity
- A7 Unstable Land
- C1 Conservation of the Nidderdale AONB
- C9 Special Landscape Areas
- C16 The Reuse and Adaptation of Rural Buildings
- GB6 Existing Dwellings in the Green Belt
- HD1 Statutory List of Buildings of Architectural or Historic Interest
- HD3 Control of Development in Conservation Areas
- HD4 Development Affecting Archaeological Sites
- HD7a Parks and Gardens of Historic Interest
- HD13 Trees and Woodlands
- HD16 Approaches to settlements
- HD18 Forecourts and Front Gardens
- HD20 Design of New development and Redevelopment
- H7 Housing Development in the Countryside
- H15 Extensions to Dwellings
- H16 Annexes to Dwellings
- R11 Public Rights of Way

Further advice on the policies and any of the issues in this document may be obtained from Planning Enquiries at the Department of Development Services.

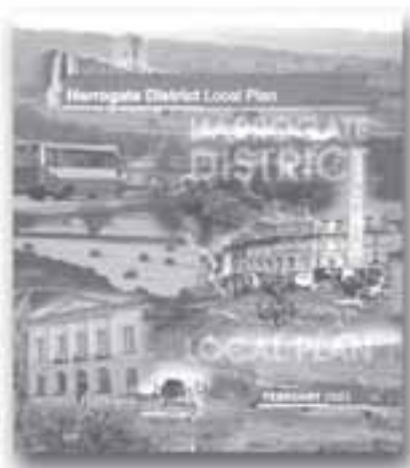

Designations

Land or buildings that are important to the built and natural heritage of the District are designated. Designations include buildings or areas of historic importance and areas of high landscape value including the Nidderdale AONB.

Listed Buildings

A Listed Building is defined by the Planning (Listed Buildings and Conservation Areas) Act 1990 as a building of architectural or historic interest which has been included in a list compiled by the Secretary of State for Culture, Media and Sport. The protection conferred by listing also covers any object or structure fixed to the building or any freestanding object or building within the curtilage. The Council have a schedule of the Listed Buildings in the District and a copy of the List Description of each.

It is an offence to demolish a Listed Building, or to extend or alter it in a manner that would affect its character without having first obtained Listed Building Consent from the local authority.

Listed Building Consent is required for all extensions and alterations to a Listed Building (both internal and external) or to buildings or structures in its curtilage, whether or not Planning permission is needed. Extensions to Listed Buildings or new outbuildings within the curtilage must be sensitively designed and of the highest quality. An application to extend a house that is listed should be accompanied by clear information to show the full implications of the extension and alterations to the fabric and character of the building. There is specific guidance available for the design of extensions and alterations to Listed Buildings.

Conservation Areas

These are defined by the Planning (Listed Buildings and Conservation Areas) Act 1990 as areas of special architectural or historic interest, the character or appearance of which it is desirable to preserve or enhance. Leaflets for each of the Conservation Areas in the District are available from Planning Enquiries.

There are additional controls to protect, restore and enhance all the elements that together make up the familiar and cherished local scene. Permitted development differs in a Conservation Area and specific controls apply to the demolition of buildings and walls, and also works to trees.



An extension to a house or a new outbuilding in or affecting the setting of a Conservation Area must be sensitively designed to ensure that it does not adversely affect the special character of the area. Buildings and extensions of only the highest quality will be appropriate to these locations.

Ancient Monuments

An ancient monument is defined by the Ancient Monuments and Archaeological Areas Act 1979 as any structure, remains of structure, or site of structure, above and below ground, which the Secretary of State for Culture, Media and Sport considers to be of public interest by reason of its historic, architectural, traditional, artistic or archaeological importance. North Yorkshire jointly with English Heritage is responsible for maintaining an up-to-date record of the archaeological sites in the District, known as the Sites and Monuments Record.

Under Section 2 of the Ancient Monuments and Archaeological Areas Act, any works affecting a scheduled ancient monument require scheduled monument consent from the Secretary of State before they can proceed. Some buildings are both scheduled and listed. Where this is the case, scheduling takes priority and it is only necessary to apply for Scheduled Monument Consent, not for Listed Building Consent. It is a criminal offence to damage or to carry out unauthorised works to an Ancient monument. Contact English Heritage before making an application.

Green Belt

Green belts are areas of land around major cities which Planning policies seek to keep permanently open. The fundamental aim of green belt policy is to prevent urban sprawl by restricting inappropriate development. Harrogate District incorporates part of the West Yorkshire (north of Bradford and Leeds) and the York Green Belts. A plan of the Green Belt is in the Local Plan.

Extensions will be permitted in the green belt only where it is shown that the scale, location and design would not detract from the open character and visual amenity of the green belt. In Green Belts house extensions that extend the ground floor area of the original house by more than 50% will not normally be permitted unless there is an exceptional household need.

Nidderdale Area of Outstanding Natural Beauty (AONB)

The Nidderdale AONB was formally designated by the Secretary of State in 1994 to give formal, statutory recognition in order to conserve and enhance the beautiful landscapes therein. The highest standards of design will be required which should reflect the local distinctiveness of the area. Outside settlements house extensions that extend the ground floor area of the original house by more than 50% will not normally be permitted unless there is an exceptional household need. Note too that permitted development rights are restricted in the AONB.

Trees

Local Planning authorities can ensure the protection of threatened trees by making Tree Protection Orders (TPOs) in the interests of amenity under the Town and Country (Trees) Regulations 1999. The Council holds TPO records.

Proposals which would involve the loss of trees that contribute to the character of a settlement will not be permitted. It is an offence to cut down, lop, top or cause other wilful damage to a tree that is subject to an order. Unless a tree that is subject to a TPO is diseased or dangerous, it is unlikely that approval will be given for cutting it down. If approval is given a replacement tree will be required.

The cutting down, lopping, topping, uprooting or other wilful damage to a tree in a Conservation Area is an offence unless the local Planning authority is given six weeks' notice of intention, during which time the authority can make a TPO.



Village Design Statements

Some villages in the District have published statements which provide additional guidance on design. At the date of publication, these are Kirkby Malzeard, Darley and Ripley. You can read copies of these on the Council's website at www.harrogate.gov.uk/harrogate-2180 (Or contact Planning Enquiries on 01423 556666 for a paper copy).

Countryside

Development will not be permitted where it would adversely affect the character or setting of Historic Parks and Gardens.

High standards of design are required in Special Landscape Areas (scheduled in the Local Plan) and on Approaches to Settlements. Buildings should reflect local distinctiveness.

Within countryside areas, which include the Green Belt and AONB, the Council considers it important that a range of housing types is maintained in accordance with national housing guidance. Extensions to dwellings have, in some areas, led to a significant reduction in the numbers of smaller dwellings. Large extensions to small dwellings alter their character, which has a detrimental urbanising effect on the rural areas. Therefore house extensions that extend the ground floor area of the original house by more than 50% will not normally be permitted unless there is an exceptional household need.

Also if the extended house would be capable of future subdivision into two dwellings, permission to extend may not be granted in order to ensure there is no circumvention of policy regarding new dwellings in the countryside.

Extensions to Dwellings for Agricultural and Forestry Workers

Where a dwelling was granted Planning permission for occupation by an agricultural or forestry worker only and restricted by condition, the normal allowance increase will not apply because it was allowed only as an exception to countryside policies. Any proposal for extension will be considered against PPG7, where the requirements of the enterprise are relevant to determining the size of the dwelling.



Existing Residential Conversions

Where the existing dwelling is an established conversion from a barn, or other rural building, a far more restricted approach will be applied. This is because of the sensitivity of the design to retain an agricultural use appearance appropriate to the countryside. An extension to a converted barn could change the building such that it appears as a new house contrary to the principle of allowing such development as an exception to the usual strict controls in the countryside. Exceptions to this may be made only where there is special justification.



Annexes to Dwellings

These are often referred to as “granny” annexes although their use varies, whether the building is for elderly dependants, teenagers or games room/study, the issues on design remain constant. Proposals to build a “granny” annex will be considered on the individual merits of the scheme. An annex may be attached or detached from the house. An annex should not have a separate vehicular access, and it should have only one bedroom. It must remain ancillary to the main house at all times, this may require a legal agreement to prevent the annex being let or sold separately.

Contact Planning Enquiries (telephone 01423 556666) for further information on the above and whether your house is affected by one or more designations.

C. Highway Issues

New extensions and outbuildings must not have a detrimental impact on highway safety. Their siting should not reduce the effective width of a footway nor impact on forward visibility of cyclists and drivers of vehicles, and in residential streets should not impact on the visibility of neighbours when emerging from their drives. Any new extension or outbuilding should ensure that adequate off-street parking is retained and particularly in locations where on-street parking is a problem.

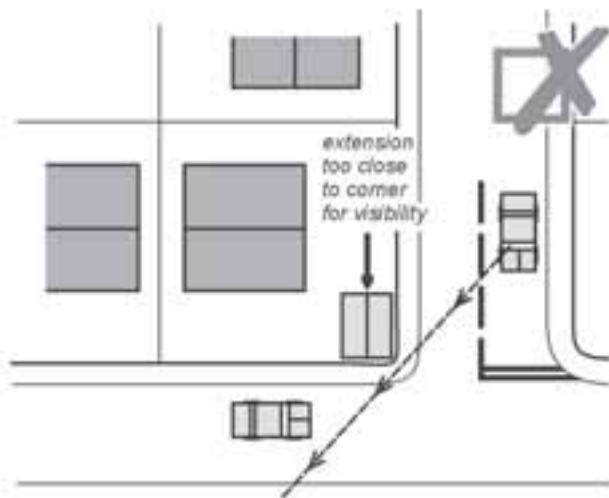

Any new vehicular access must meet the standards set in the North Yorkshire Highway Design Guide:

- A new drive should be located not less than 20m from an existing road junction with a main distributor road. New access will not be permitted where there is insufficient visibility of the road when exiting the drive.
- Within housing estates, drives should not be located upon a junction radius nor interfere with dropped kerb facilities for pedestrians.
- Accesses to classified or main distributor roads should provide or retain turning facilities for residents and visitors' cars.
- A new or altered access to any classified road requires Planning permission in its own right, if necessary, in an independent Planning Application.
- Proposals to construct walls and fences more than 1.0m high adjacent to a highway also require Planning permission in their own right.
- A garage door should be a minimum of 6m back from the front boundary to allow a parked vehicle in front.

- Gates, doors and windows must not open out onto the footway or access.
- Drive gradients steeper than 1 in 12 will result in difficulties for the disabled and may result in vehicles "grounding".
- Minimum recommended drive width is 2.7m.
- Construction of an amended or new vehicle crossing over the footway can only be done with Planning Permission *and* with a separate licence from the Highway Authority.
- Special consideration should be given to intervisibility between cars and pedestrians where the drive meets the footway and the drive or the footway are busy (e.g. close to a local school).

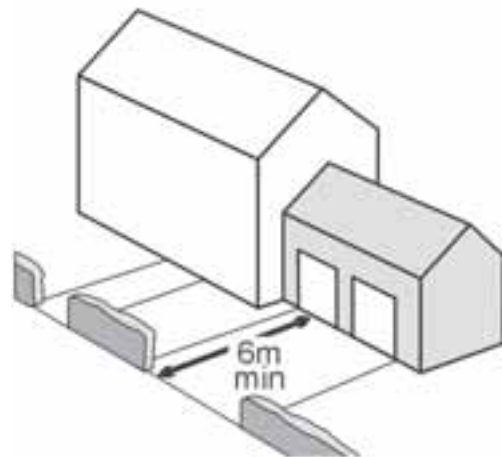

D. Relationships Between Buildings

This information is applicable to most twentieth century housing estates, however each individual case will be considered on its own merits. Development should be appropriate to its context. The local grain and character of an area may be such that the dimensions given below are inappropriate. In the centre of towns where the grain is tight new development may be closer to neighbouring buildings, and conversely new development in areas of very loose grain should maintain larger gaps between buildings. However, in all cases it will still be necessary to ensure reasonable amenity levels.

The guidance given here relates to Neighbour Effect only and addresses the issues of Overlooking, Overshadowing and Overbearing. The examples are based on a flat site of no particular orientation.

With regard to Overlooking, the use of the room is taken into consideration. The principle windows to lounges, dining and other such reception rooms are classed as Main Windows. Those to bedrooms are Secondary Windows. Kitchens and utility windows are Tertiary Windows. As privacy is not so critical in Kitchens, the distances between facing windows can be reduced.

Recommended distance between windows to provide internal privacy

Ground Floor Main:	Main	21m
	Secondary	18m
	Tertiary	15m
Secondary:	Secondary	15m
	Tertiary	12m
Tertiary:	Tertiary	7.5m

This distance may be reduced in cases where the view is not directly opposite the window, but at an oblique angle. At angles more oblique than 45°, there is no minimum distance recommended. This distance will be increased when the proposed floor levels are higher than neighbouring floor levels by 1m for each metre in height difference.

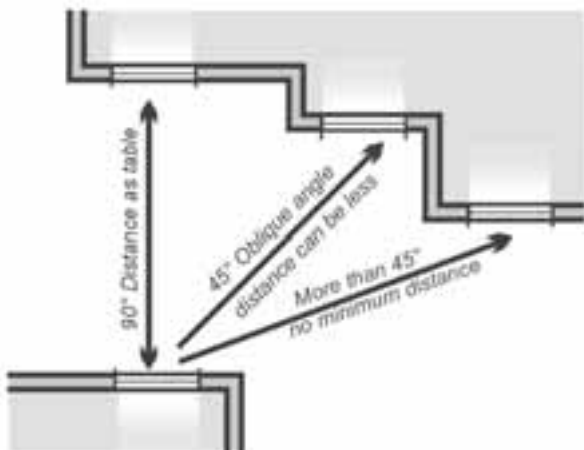

Recommended distances to provide reasonable external privacy

Overlooking of the private garden of a neighbouring property is to be avoided. A first floor bedroom window should be at least 7.5m from a boundary and a first floor lounge window should be at least 12m from a boundary.

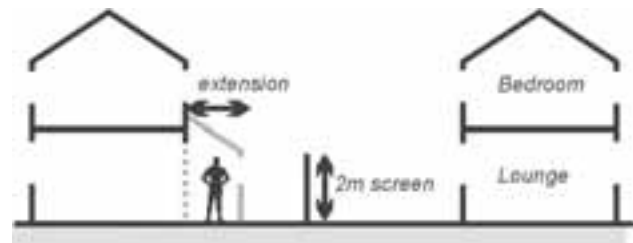
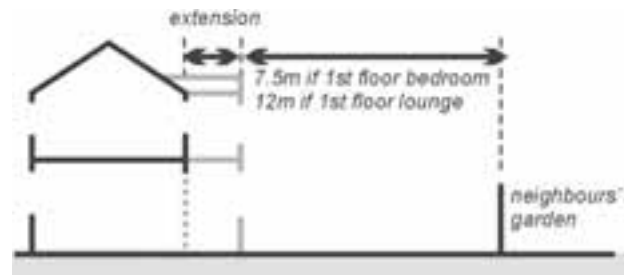

The erection of a 2m high wall or fence can provide a privacy screen between ground floor windows and also gardens.

Effect of differing ground or floor levels

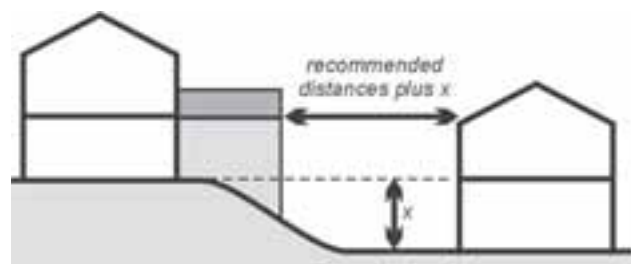

As a guide: for each metre of height difference there should be an extra metre horizontal distance.

Guidelines to distances to prevent overbearing and excessive overshadowing

Proposed extensions and outbuildings must be designed to ensure that they do not have a significant detrimental impact on neighbours light by avoiding unacceptable levels of overshadowing of windows and significant areas of garden. Usually some overshadowing cannot be avoided where properties are attached or sited very close to one another.

Where it appears that overshadowing may be significant, applicants will need to show that overshadowing is within acceptable limits. It is recommended that the applicant follows the guidelines in the Building Research Establishment's document entitled "Site Layout - Planning for Daylight" by P.J.Littlefair.

The following diagrams are based on 20th Century housing estates and therefore will not be appropriate in all situations. Local character may dictate larger dimensions, or smaller dimensions may be acceptable in areas of tight grain. Where not specifically indicated, this information should be used in conjunction with the recommended distances between windows where the extension has windows on that side.

The diagrams indicate development that should not cause unacceptable levels of overshadowing. The diagrams are based on the assumption that the site is flat and level with the neighbouring property and also that storey heights are modest. Note however that orientation will be taken into account because an extension to the south of a neighbouring property will have far more impact than one to the north.

Single Storey Extension to Attached House (either terrace or semi-detached house)

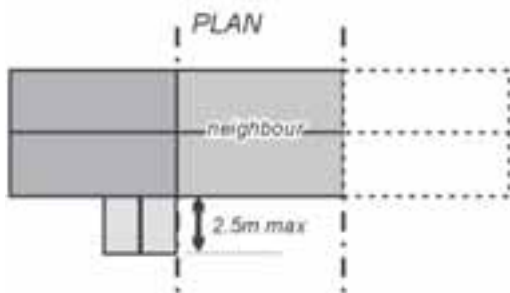

Single Storey Extension to Detached House

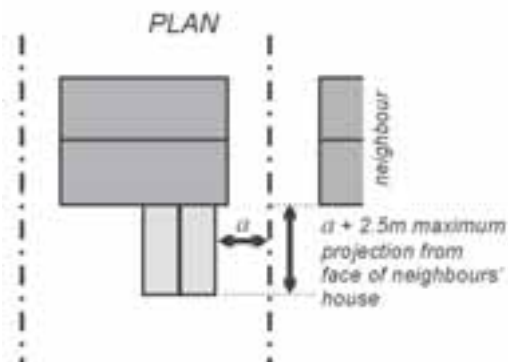

Two Storey Extension to Detached House

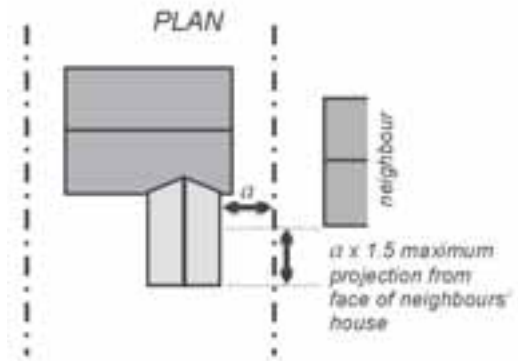

It is unlikely that a two storey extension will be acceptable directly on a joint boundary. It is suggested that the neighbour of the adjoining house is approached and asked to consider a joint extension that can comply with this guidance.

Combined Extension of Two Neighbouring Houses in a Terrace

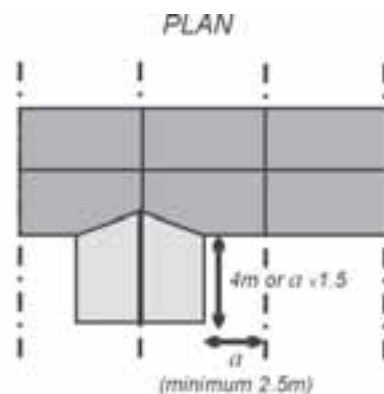

The same principle applies to outbuildings, particularly when set less than 5m away from the house. This diagram is based on an outbuilding similar in height to a shed or low garage. If it is taller, greater distances apply.

Single Storey Outbuilding in Garden

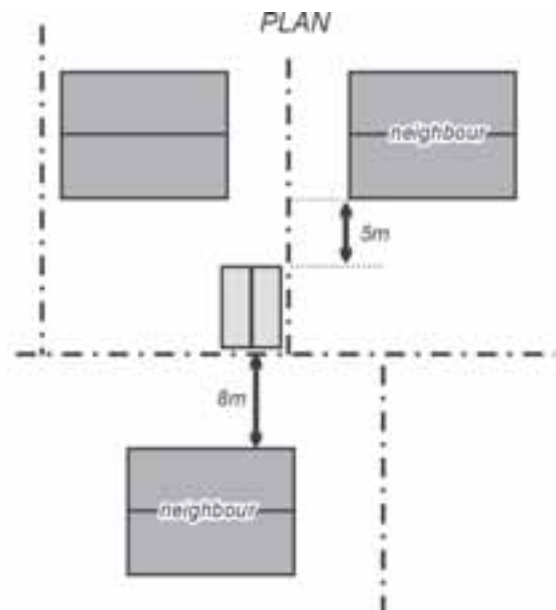

Relationship of extensions to neighbouring houses

Please note, these are guidelines based upon the premise that the floor levels of the extension are at the same level as neighbouring floor levels, and that the ground between is relatively flat. As a guide, the dimension between buildings should be increased by at least 1m for each metre that the proposed extension floor level is above neighbouring levels. Also note, these distances will be increased if the extension impacts upon the southern aspect of a neighbour's garden.

Two Storey Rear Extension with no windows to rear

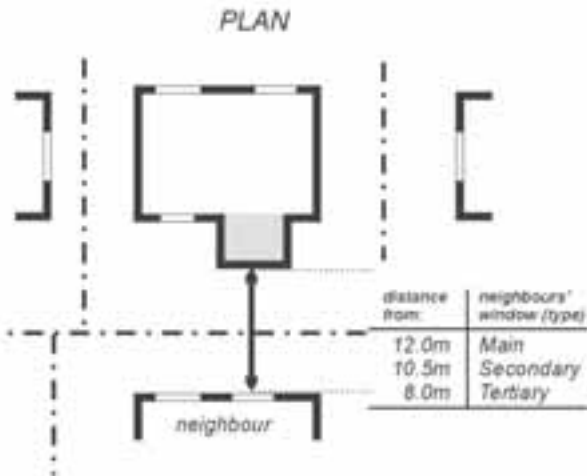

Two Storey Rear Extension with rear windows

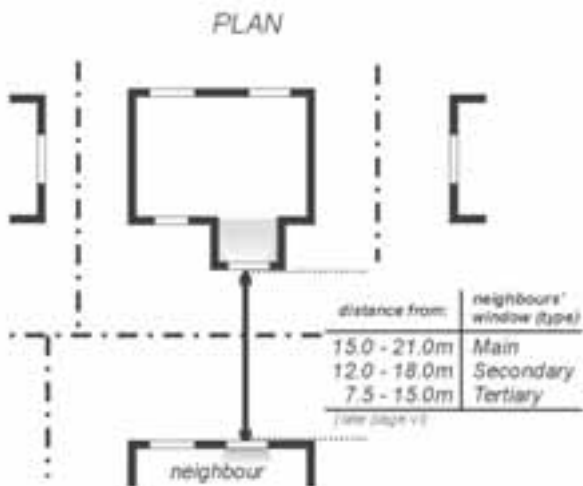

(Note: there will be a presumption against two storey extensions up to the boundary)

Single Storey Rear Extension with no windows to rear

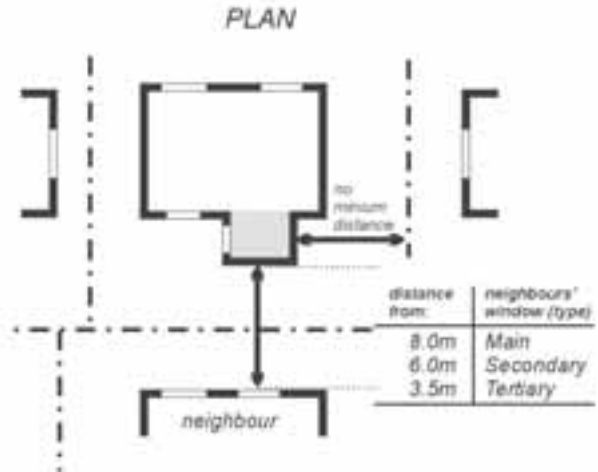

Single Storey Rear Extension with rear windows

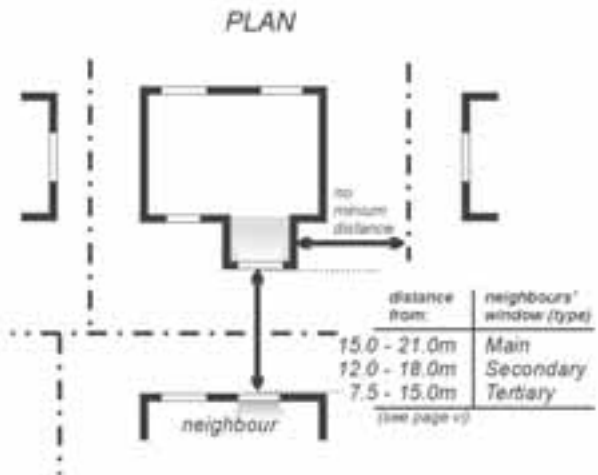

Single Storey Rear Extension against boundary of neighbours' garden

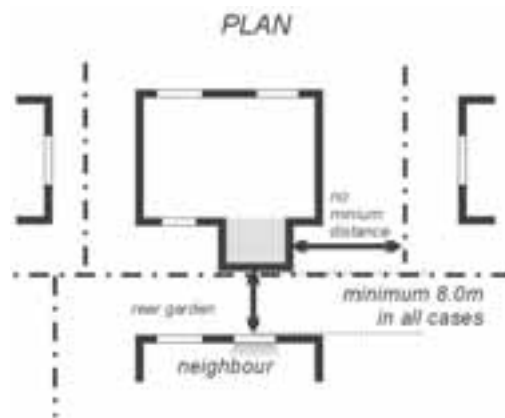

Single Storey Side Extension with no side windows

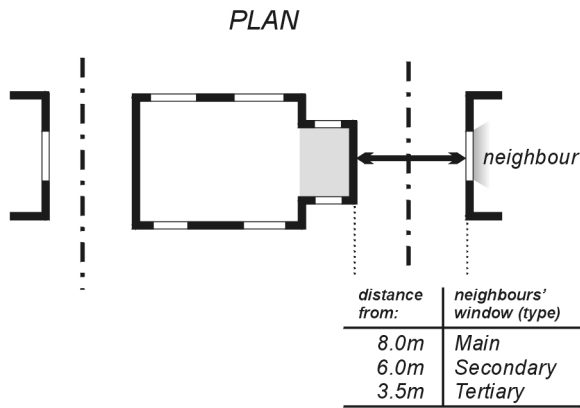

Two Storey Side Extension with no side windows to either property

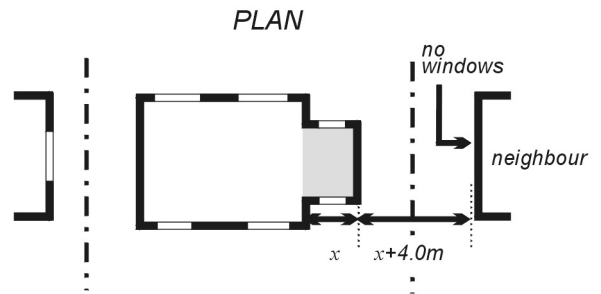

Two Storey Side Extension with no side windows

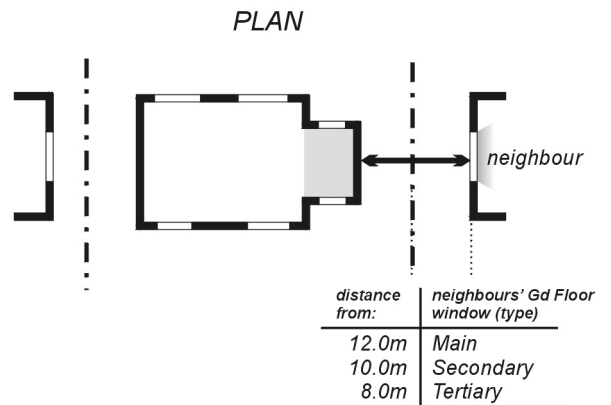

Single Storey Side Extension against side boundary

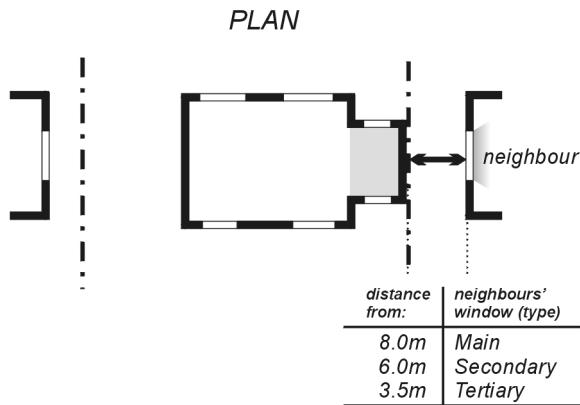

Two Storey Side Extension with side windows

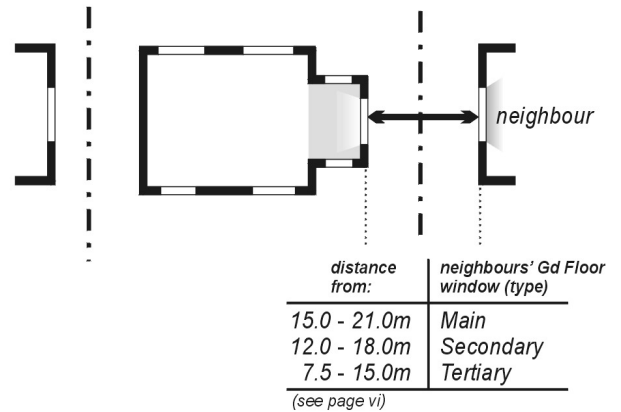

Single Storey Side Extension with side windows

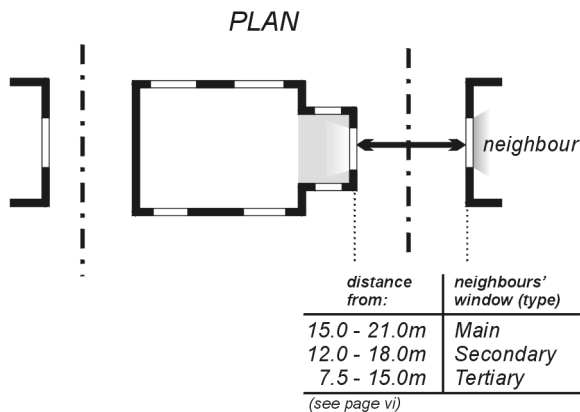

(Note: there will be a presumption **against** two storey extensions up to the boundary.)

E. Building Form Composition -

Side Extensions to Detached Houses

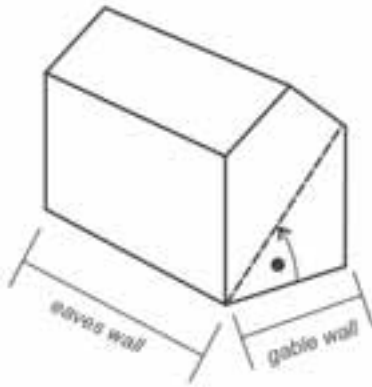

BASIC HOUSE

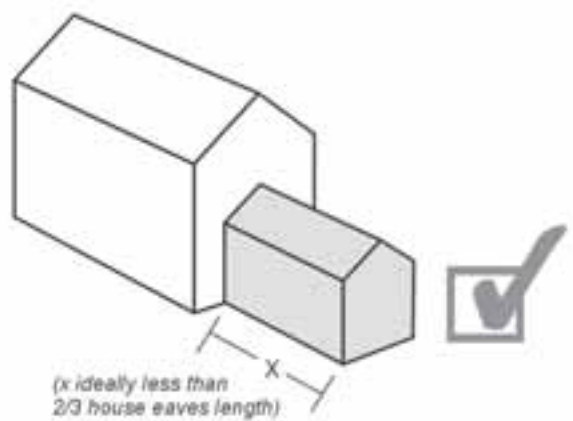
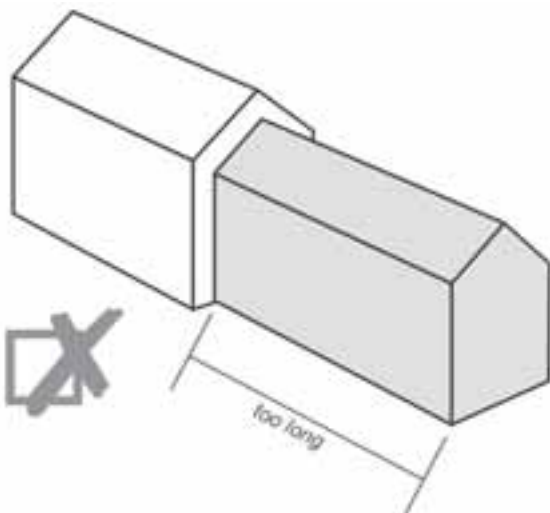
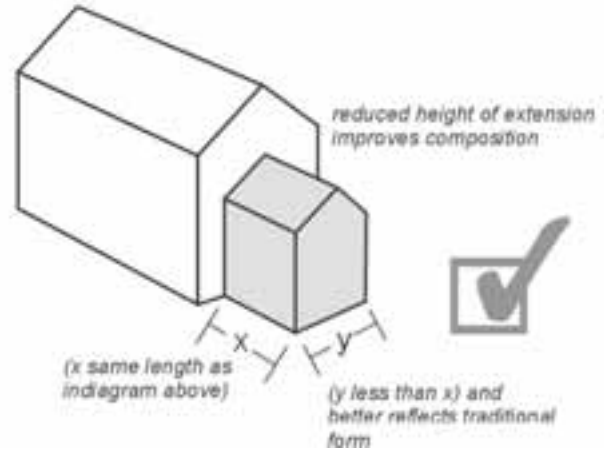
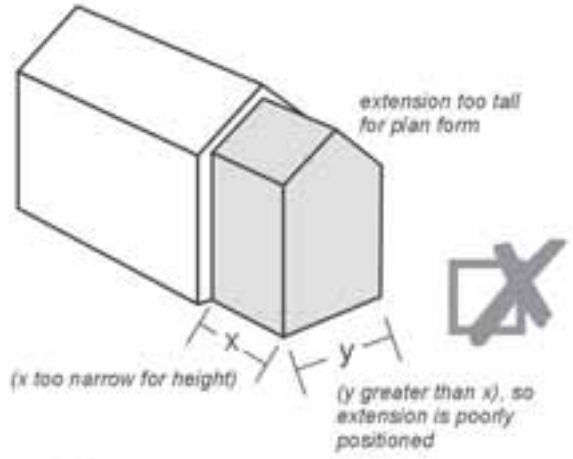
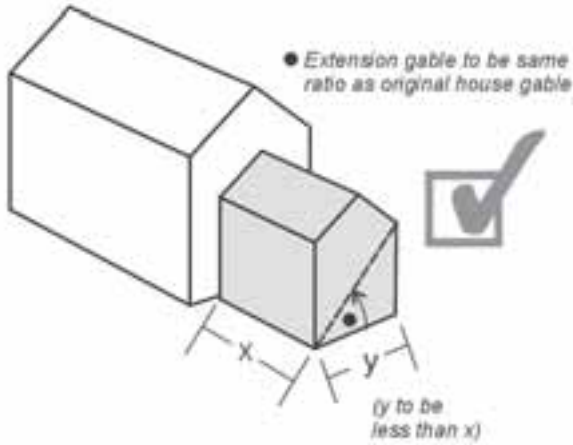

Rear Extensions to Detached Houses

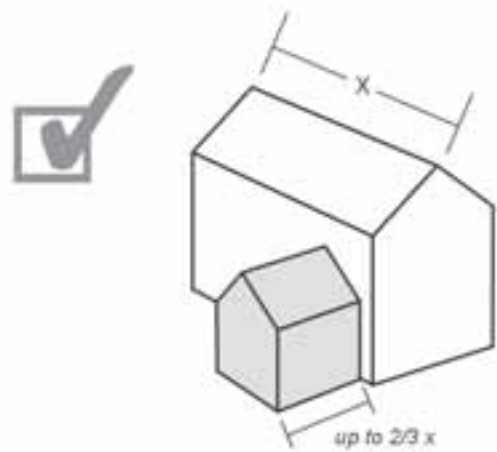
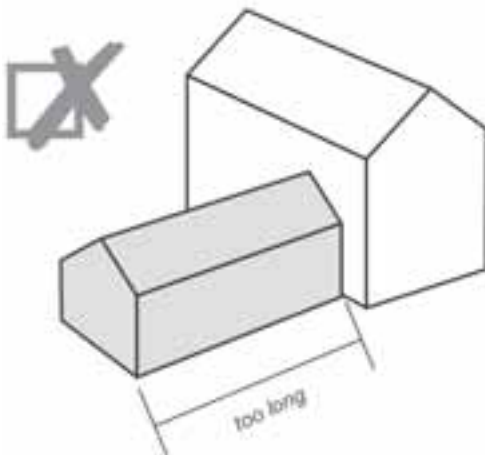
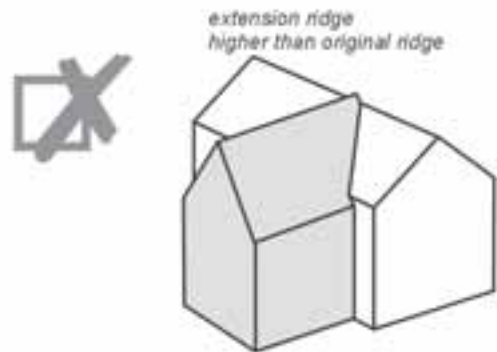
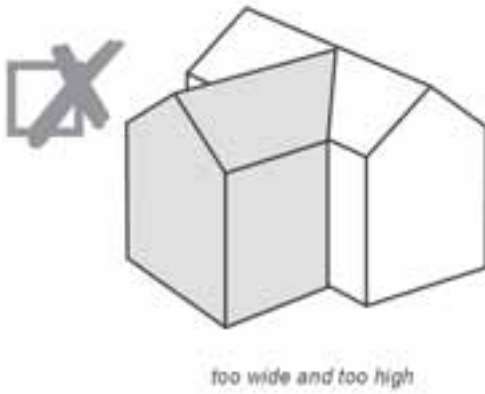
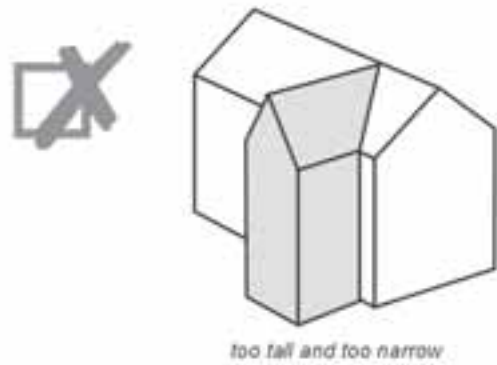
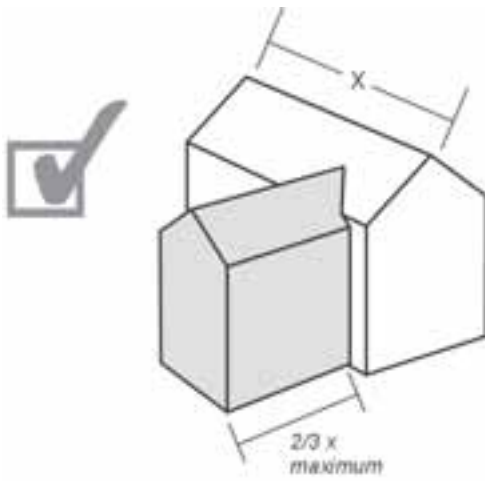

F. Detail of Junction between House and Extension

Brick Walls



ORIGINAL HOUSE

EXTENSION

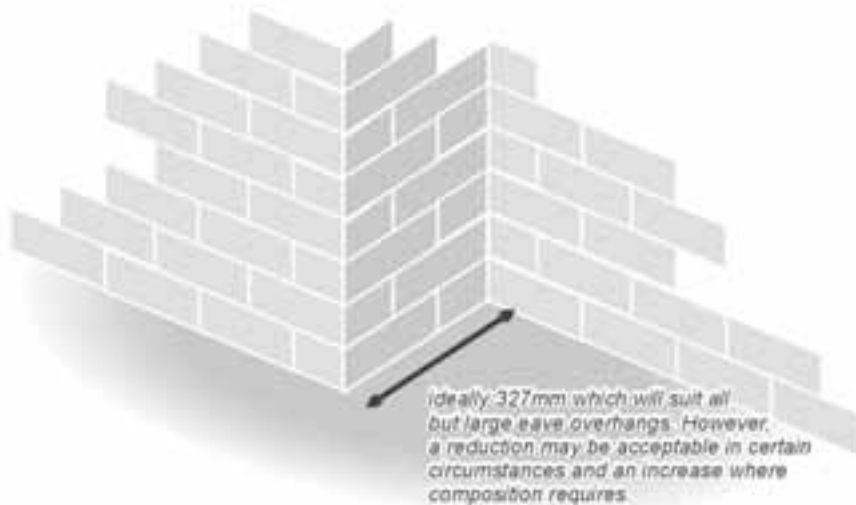

ideally, 327mm which will suit all but large eave overhangs. However, a reduction may be acceptable in certain circumstances and an increase where composition requires

Stone Walls

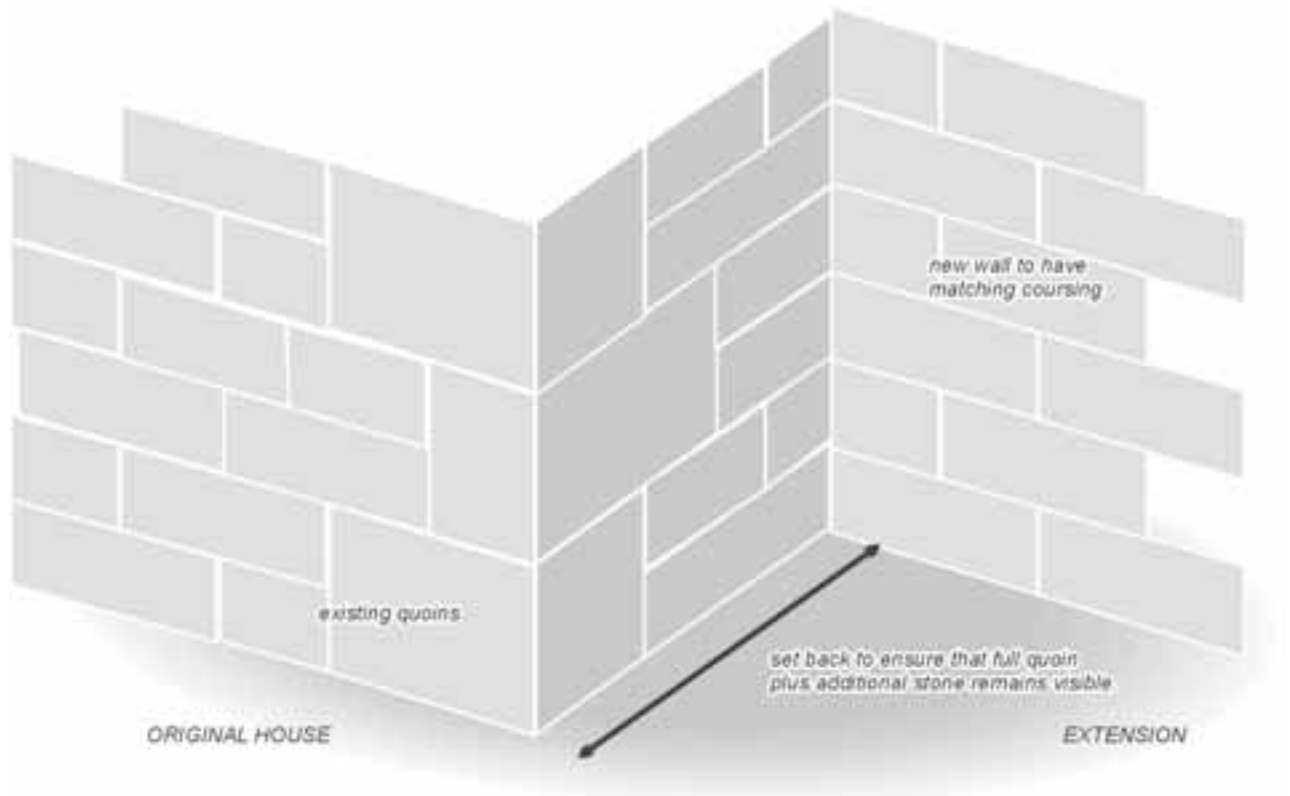

Brick and Cobble Walls

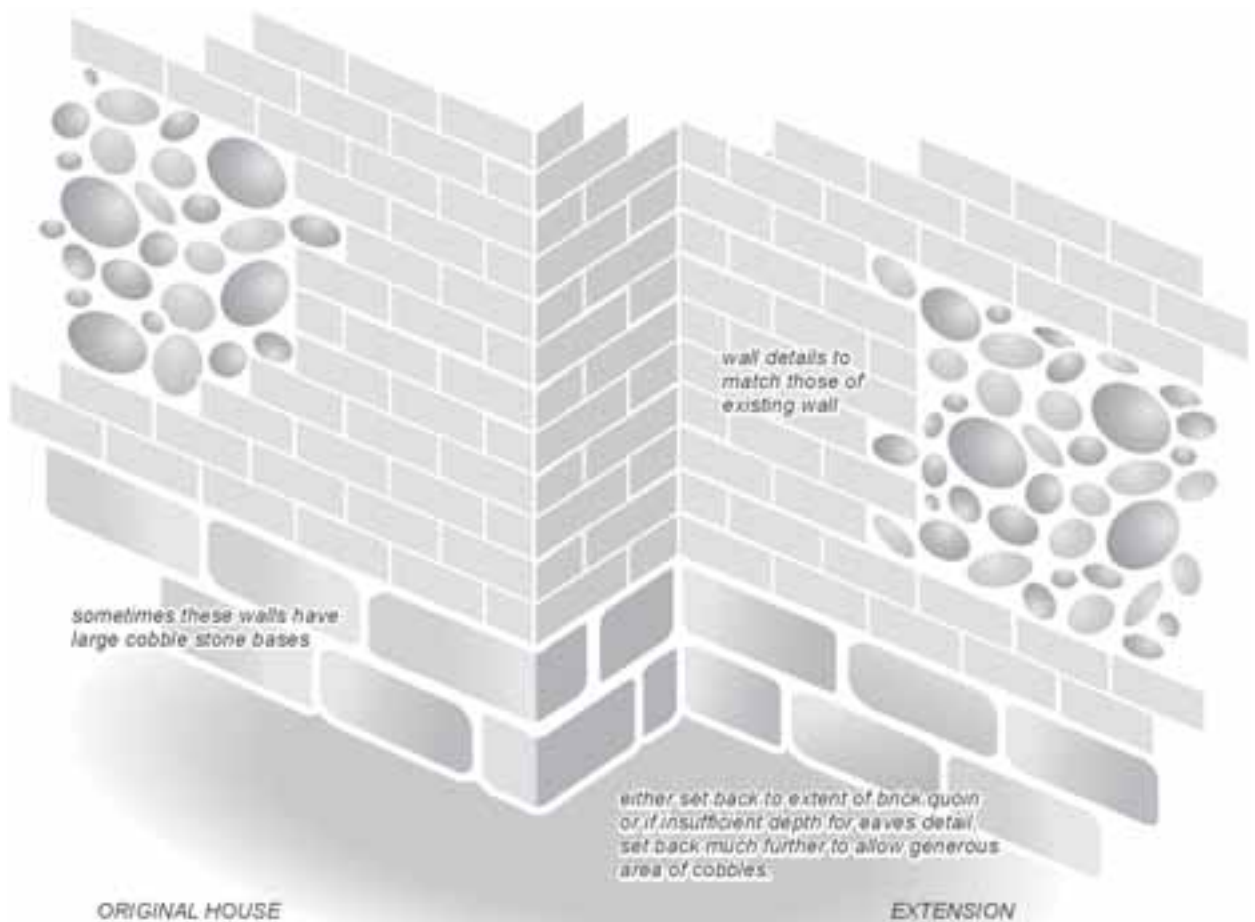

G. Definitions

Amenity (see also 'Residential amenity')

Amenity is the pleasantness or enjoyment of a building or area. Factors that may impact on amenity include pollution, traffic, and poorly designed and over-intensive development.

Catslide

A catslide is a section of roof that falls the same direction as the remainder of the roof but at a lower pitch, usually to accommodate a dormer. If the pitch of a dormer is not significantly lower than the remainder of the roof, it has less visual impact than one with a flat roof or with a roof at right angles to the main roof.

Development

For the purposes of this guide, the term development refers to extensions, roof alterations, outbuildings and any enclosed space within a residential curtilage.

Enclosed space

Buildings clearly enclose space, however space is also enclosed by open roofed areas and raised decks. Planning consent may be required for a car port, balcony or garden deck dependant on the volume of space that is enclosed. Where a deck or balcony is raised above natural ground level, a volume of space is enclosed underneath. The void and any balustrade have a visual impact and may cause overlooking or overshadowing of neighbouring property.

Local distinctiveness

Local Distinctiveness derives from environmental factors that contribute to the character of an area and which distinguish one locality from another. These factors may range in scale from the encompassing landscape right down to the tiniest detail of construction. The size of an area is not relevant, the term can be applied to extensive tracts of countryside as well as to very small areas of a town which display their distinctive character.

It is possible for locally distinct areas to have some elements of character similar to other areas, for example the basic form of buildings, their relationship to the street and the spaces between them in Kirkby Malzeard have a similarity with those of Tockwith, but the materials and constructional details of buildings and their boundary treatments are very different. The materials and details in Kirkby Malzeard are similar to nearby villages in the West of the District, but further detailed study shows for example that the village has very distinctive porch canopies on houses owned by one estate. These factors contribute to an area's individuality and to its sense of place.

Massing

This is the three dimensional expression of a development. It is the combined effect of the arrangement, volume and shape of a building, or part thereof. Occasionally the term "bulk" is used instead of the term "mass" in the context of buildings.

Residential amenity

Residential amenity refers specifically to the enjoyment by the user of a dwelling and its domestic curtilage. The impact of external factors on a user's well-being is considerable when they affect his/her home and garden. New development should not significantly reduce privacy and light, which are important elements of residential amenity, nor be visually oppressive.

Setting

The immediate surroundings of a building in terms of its natural and built environment. Principally landscape (including topography and plant species etc) and the disposition and design of other buildings close by.

Size

In assessing size, the Council will use the following criteria:

- All measurements to be external
- The size of the original house will be taken to be the dwelling as originally built and excludes any subsequent extensions or outbuildings. In certain circumstances, a limited allowance may be made for permanent and substantial outbuildings where they are proposed to be removed as part of the development.

External volume will include dormers, bay windows, chimneys that protrude beyond the outer wall and any areas covered by permanent roof.

Streetscene

The disposition and design of buildings and the nature of spaces and planting between together make up the character of the public realm. Although usually applied in urban areas, the term "streetscene" can also be used in relation to houses along a country lane. It would not, however, apply to small scale development in the open countryside.

Primary, secondary and tertiary windows

"Primary windows" are the main ones found in lounges, dining and other reception rooms; "secondary windows" are those found in bedrooms, studies and side/additional windows to lounges; "tertiary windows" are those in kitchens, bathrooms and side/additional windows to bedrooms or studies.

H. Consultation Process

On 30 September 2005 Harrogate Borough Council adopted the House Extensions and Garages Design Guide Supplementary Planning Document (SPD).

This SPD has been prepared to expand on saved policies H15 and HD20, and provide further advice to applicants, officers and members on the key principles of good design. The SPD will form part of the planning framework for the District. As SPD, it does not have development plan status nor is it subject to independent examination. However this guidance has been subject to statutory procedures in terms of its preparation and hence will carry greater weight than guidance that has not been through this procedure.

A Sustainability Appraisal (SA) of the SPD was prepared and consulted on at the same time as the draft SPD. It identified the environmental, economic and social effects of the House Extensions and Garages Design Guide SPD, so that decisions can be made in accordance with the objectives of sustainable development. The SA incorporates the requirements of the Strategic Environmental Assessment Directive (European Union Directive 2001/42/EC).

A formal public consultation on the Draft SPD and accompanying SA was carried out between 26th April 2005 and 10th June 2005. Both documents were available for public inspection at the Council's Department of Development Services and in libraries throughout the District, including mobile libraries. Notice of the consultation was given by means of local advertisement advising of when and where the documents could be inspected. Parish Councils, Statutory Consultees as described in PPS 12: Local Development Frameworks, adjacent authorities, environment and amenity groups and other interested stakeholders (including developers, planning and design agents who regularly make application to this authority) were consulted during this period. Members of the Planning Committee were notified and asked to pass on comments before the end of September 2005.

The Council received responses to the SPD from 14 consultees and 1 response was submitted regarding the SA. The information in the Sustainability Appraisal and the responses to the consultation have been taken into account before the SPD was adopted. Copies of the reports are available on request to the Department of Development Services.

Arrangements have been made for the Council to carry out the requirements of Regulation 19 of the Town and Country Planning (Local Development) (England) Regulations 2004 and the Harrogate District Draft Statement of Community Involvement (June 2005) following the adoption of the SPD, which include making the SPD, SA, Consultation Statement, and Adoption Statement available to view in public libraries and council offices across the district. Additionally the SPD and associated documents (listed above) will be published on the Council's Website at www.harrogate.gov.uk/localdevelopmentframework.

Arrangements for monitoring are contained in the sustainability appraisal report. The effects of the SPD will be monitored and reported on annually. If monitoring reveals adverse effects then appropriate remedial action will be taken.

I. List of Useful Contacts

Government policies and guidance

Office of the Deputy Prime Minister
26 Whitehall
LONDON SW1A 2WH
Tel: 020-7944-4400
e-mail: planning.policies@odpm.gsi.gov.uk
website: www.odpm.gov.uk

Listed buildings, Scheduled Ancient Monuments, Conservation Areas, Protected trees, Nidderdale AONB, Building Control and private Drainage. Highways in agency area of Harrogate and Knaresborough

Planning Enquiries
Harrogate Borough Council
Department of Development Services
Knapping Mount,
West Grove Road,
HARROGATE HG1 2AE
Tel: 01423-500600
e-mail: dds@harrogate.gov.uk
website: www.harrogate.gov.uk/planning

Highways outside the agency area of Harrogate and Knaresborough

North Yorkshire County Council
County Hall
NORTHALLERTON
North Yorkshire DL7 8AD
Tel: 01609-780780
website: www.northyorks.gov.uk
or: www.findingyorkshire.org.uk

Adopted Drainage

Yorkshire Water
P.O. Box 52
BRADFORD BD3 7YD
Tel: 0845-124-2423
website: www.yorkshire.water.co.uk

Flood Risk

Environment Agency
Coverdale House
Aviator Court
Amy Johnson Way
Clifton Moor
YORK YO30 4U2
Tel: 08708-506506
e-mail: enquiries@environment-agency.gov.uk

Applications for Scheduled Monuments Consent

English Heritage
23 Savile Row
LONDON W1X 1AB
website: www.english-heritage.org.uk

Protected Species

English Nature
Genesis Building
University Road,
Heslington,
YORK YO1 5OQ
Tel: 01904-435500
e-mail: york@english-nature.org.uk
website: www.english-nature.org.uk

Crime Prevention

North Yorkshire Police
Community Safety Department
Police Station
North Park Road,
HARROGATE HG1 5PJ
Tel: 01423-539473
website: www.northyorkshire.police.uk

J. Application Checklist

- a) Have the site and existing building/s been surveyed and appraised in accordance with the Site Appraisal Guidance?
- b) Has the siting and plan been devised to:
- Reflect and reinforce the general pattern of settlement?
 - Provide adequate space around the building and ensure usable amenity space?
 - Preserve existing valuable site features?
 - Maintain an adequate standard of visibility for road users
 - Maintain the access from the highway and space for car parking?
 - Protect neighbouring amenities?
 - Give or maintain maximum natural surveillance for crime prevention?
 - Provide for disabled access if necessary?
- c) Does the form of the building:
- Respect the form and scale of the existing building and adjacent buildings?
 - Relate to existing precedents in the area where appropriate?
 - Present a built form of good individual proportions and good overall composition?
 - Give a satisfactory roofscape?
 - Ensure there is no significant reduction of daylight and sunlight enjoyed by neighbours?
- d) Does the external appearance:
- Accurately reflect the form and character of the original building and adjacent buildings, or represent good contemporary design as appropriate?
 - Represent a balanced and well resolved design?
 - Have a balanced pattern of windows and doors in the facades?
 - Ensure that neither windows nor balconies will invade the privacy of neighbours
 - Use the appropriate range of materials and have well resolved details, suitable to the form and character?
- e) Does the landscape treatment:
- Retain existing valuable landscape features?
 - Enhance the setting of the house and, in particular, maintain or enhance the boundary treatment?
 - Provide any necessary screening in an appropriate and well-designed manner?

K. Information required to be submitted with Application

Applications for Full Planning Permission should be submitted with plans showing what is existing and what is proposed. The following list is based upon "Best Practice Guidance on the Validation of Planning Applications" (March 2005) ODPM:

- The completed application forms and necessary certificates and notices.
- Location Plan based on an Ordinance Survey at a scale of 1:1250 or 1:2500 the direction of north, marked. The application site boundary shown in red, (including all land necessary to carry out the proposed development) and nearby land in the same ownership in blue.
- Site Plan to a scale of 1:100, 1:200 or 1:500 showing boundaries, existing buildings, parking and access, boundary treatment and extent and type of hard surfacing, refuse storage and drainage. Also buildings on adjoining sites. Trees within 12m of proposed building works.
- Floor Plans at 1:50 or 1:100 to explain the proposal in detail. Where existing building or walls are to be demolished these should be shown. The extension should be shown in context with adjacent buildings.
- Existing and Proposed Elevations of all sides of the proposal at 1:50 or 1:100 to show the proposed works in relation to the original house. The elevations should indicate the proposed building materials and style, materials and finish of windows and doors. Where an extension is close to another house the drawings should show the relationship between buildings and detail the position of openings of neighbouring properties.
- Cross Sections at 1:50 or 1:100. Where there is a change in ground level, drawings should show existing and proposed levels. On sloping sites, full details of levels of the building, the adjacent ground and neighbouring properties is required.

Further information required by the Council could include:

- Design Statement (advice is given in "By Design - Urban Design in the Planning System" (May 2000) CABE for ODPM).
- Arboriculturalist Statement.
- Flood Risk Assessment/drainage strategy if the site falls within a Flood Zone (as shown on Environment Agency maps).
- Conservation Area Appraisal (advice is given in English Heritage Guidance "Conservation Area Practice" Section 4).
- Sunlight and Daylight Assessment based on the Building Research Establishment's "Site Layout - Planning for Daylight".
- Assessment of Archaeological Features.

Agents

The use of a professionally qualified agent is strongly advised. Agents can provide good value for money, and can achieve the best value from the site. When choosing an agent, check the quality of previous commissions, find out if the designer is sympathetic to your own approach and is familiar with the Council's procedures and can produce drawings and information as required by the Planning Division.

Specific advice on how to make a Planning application is included in our Planning Application Pack. You can download the 'Checklist and Notes' part of this Pack from our website at: www.harrogate.gov.uk/harrogate-1030 . Or, contact Planning Enquiries (phone 01423 556666) and ask for a Planning Application Pack which includes the advice along with relevant application forms.